

# SKIPPER GDS101

## Graphic Depth Sounder Operation And Installation Manual

Edition : 20081124sw5.05.06



Skipper Electronics A/S      Telephone      +47 23 30 22 70  
Ryensvingen 5      Telefax+47 23 30 22 71  
P.O.Box 151, Manglerud      E-mail: skipper@skipper.no  
0612 Oslo, Norway      Co.reg.no: NO-965378847 -MVA  
[www.skipper.no](http://www.skipper.no)

# SKIPPER

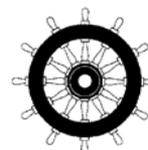

*Weitergabe sowie Vervielfältigung dieser Unterlage, Verwertung und Mitteilung ihres Inhaltes nicht gestattet, soweit nicht ausdrücklich zugestanden. Zuwiderhandlungen verpflichten zu Schadenersatz.*

*Copying of this document, and giving it to others and the use or communication of the contents thereof, are forbidden without express authority. Offenders are liable to the payment of damages.*

*Toute communication ou reproduction de ce document, toute exploitation ou communication de son contenu sont interdites, sauf autorisation expresse. Tout manquement à cette règle est illicite et expose son auteur au versement de dommages et intérêts.*

*Sin nuestra expresa autorización, queda terminantemente prohibida la reproducción total o parcial de este documento, así como su uso indebido y/o su exhibición o comunicación a terceros.*

*De los infractores se exigirá el correspondiente resarcimiento de daños y perjuicios.*

# CONTENTS

<b>1. INTRODUCTION.....</b>	<b>5</b>
System Summary.....	5
<b>TRANSDUCERS.....</b>	<b>5</b>
<b>OPERATOR PANEL.....</b>	<b>5</b>
<b>DATA ENTRY.....</b>	<b>5</b>
<b>RECORDED DATA STORAGE.....</b>	<b>5</b>
Fig. 1.1 Main Display Unit Panel Layout.....	6
Fig. 1.2 System Diagram.....	7
<b>INTERFACING.....</b>	<b>8</b>
Outputs.....	8
Inputs.....	8
<b>ALARMS.....</b>	<b>8</b>
<b>HISTORY MEMORY.....</b>	<b>8</b>
<b>OPTIONS.....</b>	<b>8</b>
Repeaters.....	8
Remote Sounding Control.....	8
Auto Range.....	8
Sound Speed Calibration.....	8
<b>GDS101 PRIMARY FUNCTIONS.....</b>	<b>9</b>
<b>2. OPERATION.....</b>	<b>10</b>
<b>PARAMETER ENTRY.....</b>	<b>10</b>
Example of parameter entry.....	11
<b>OPERATION SCREENS.....</b>	<b>11</b>
Primary operation Screens.....	12
Secondary operation screens.....	15
<b>PRINCIPAL FUNCTIONS.....</b>	<b>22</b>
Bottom detection.....	22
Ping to Ping filtering.....	22
Bottom Search Range.....	22
Power ON/OFF.....	22
<b>FIXED KEY FUNCTIONS.....</b>	<b>23</b>
Depth Range.....	23
Picture Speed.....	23
Menu.....	23
Day / Night & Back light adjustment.....	23
<b>SOFT KEY FUNCTIONS.....</b>	<b>24</b>
Gain.....	24
TVG.....	24
Digital indication.....	24
Frequency.....	24
Output Power.....	24
Draught.....	24
External Printer Operation.....	24
Alarm settings.....	25
Clock and Calendar Settings.....	25
History Memory.....	25
Simulator.....	26
Status Screen.....	26
Oscilloscope Screen.....	26
Non-volatile Parameter Memory.....	26
<b>OPTIONS.....</b>	<b>27</b>
Repeaters/Slaves.....	27
Remote Sounding Control.....	27
Auto Range.....	27
Sound speed calibration.....	27
External Printer.....	27
<b>3. USER MAINTENANCE.....</b>	<b>28</b>

TRANSDUCER MAINTENANCE.....	28
OPERATOR UNIT MAINTENANCE.....	28
TYPICAL STATUS SCREEN (9) CONTENTS.....	30
TYPICAL OSCILLOSCOPE SCREEN (10) CONTENTS.....	32
<b>4. INSTALLATION .....</b>	<b>35</b>
STANDARD SYSTEM SUPPLY.....	35
TRANSDUCER INSTALLATION.....	35
Location.....	35
Installation Details.....	35
TRANSDUCER JUNCTION BOX.....	37
OPERATOR UNIT INSTALLATION.....	38
Back-up Battery Jumper.....	41
Power Indication and function LEDs.....	42
INTERFACING.....	44
Alarm relay.....	44
External alarm reset function.....	44
Log Pulse input.....	45
Remote Transducer Selector FEEDB (Feedback).....	45
Transmitter and Bottom Pulse outputs.....	45
Analogue interfaces.....	45
NMEA interface.....	46
External Interface Ports.....	48
OPTIONS.....	49
Repeaters/Slaves.....	49
Remote Keyboard.....	49
Remote Sounding Control.....	49
<b>5. START-UP AND SYSTEM ADAPTATION.....</b>	<b>50</b>
SYSTEM ADAPTATION.....	50
Analogue Output And Log Pulse Input Range Selection.....	50
Language and Units of Measure.....	50
Remote Transducer Selector.....	50
Low frequency indication.....	50
NMEA Setup.....	51
OPTIONS.....	52
Calibration, Sound Speed.....	52
External Ping Control.....	52
<b>6. SPECIFICATIONS DIMENSIONS .....</b>	<b>53</b>
FUNCTIONAL PROPERTIES.....	53
<b>7. SERVICE.....</b>	<b>55</b>
CPU Board Setup Procedure.....	55
MASTER RESET PROCEDURE.....	58
<b>8. APPENDIX MISCELLANEOUS INSTALLATION DRAWINGS.....</b>	<b>59</b>

# 1. INTRODUCTION

## System Summary.

GDS101 is a navigation sounder with a large, high resolution graphic LCD. The echosounder graphics are continuously shown on the LCD along with complete navigational details.

The Color Bar :

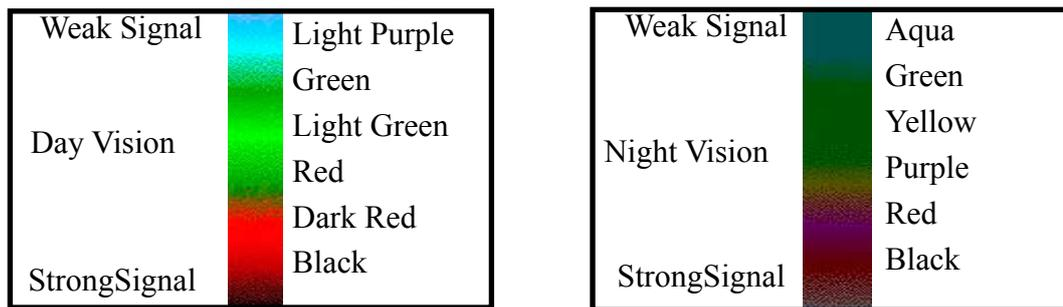

It is possible to connect an external printer to the operator unit. The sounder contains a 24 hour history memory. That can be printed out. Depth, time and all available navigation data are stored continuously so that the last 24 hours of information is always available.

All this information may also be printed on the external printer. All IMO requirements are met or exceeded. Comprehensive interfaces are available including NMEA0183 inputs and outputs.

## TRANSDUCERS.

GDS101 is prepared for connection of the following transducers: 38, 50 and 200 kHz. One or more of the transducers may be connected at the same time, and the desired transducer may be selected from the operator panel.

## OPERATOR PANEL.

The operator unit contains a graphic dot-matrix supertwist LCD display and a keyboard with fixed keys, soft-keys and a rotating encoder. The function of each soft-key button depends on the active screen, and the buttons are labelled on the lower rim of the LCD. The display is backlit, and contrast and backlight intensity may be adjusted by the user. The echo-gram is normally displayed continuously on the LCD and stored in the 24 hour history memory. An optional external printer is used if hard-copy documentation is required. The operator unit is normally flush mounted. Power supply options are 115/230V AC or 24V DC. The power consumption is appx. 70 Watts at 115/230V AC or 50 Watts at 24V DC.

## DATA ENTRY.

Several screens may be selected to enter various settings and calibration parameters. Each screen has a selection of soft-key buttons.

Screens 1 through 3 are primary operation screens with appropriate operator controls. Screens 4 through 10 are calibration set-up and system supervision screens.

The various screens will be described in detail later.

## RECORDED DATA STORAGE.

The displayed echogram and other navigational data is continuously stored in the 24 hour history memory.

A standard printer type HP. or Epson may be connected for paper copy, Ask Skipper Electronics for specification.

Since the printer is only required when hard copy documentation is absolutely necessary, the paper consumption is expected to be limited under normal conditions.

## **WARNING!** False bottom echoes may occur when :

- The bottom is out of range.
- Extreme noise conditions are present.
- Bottom signal may be lost for other reasons, like wakes, or aeration below transducer.

The bottom line shown on the GDS 101 screen is a synthetic signal, made by the sounder's computer.

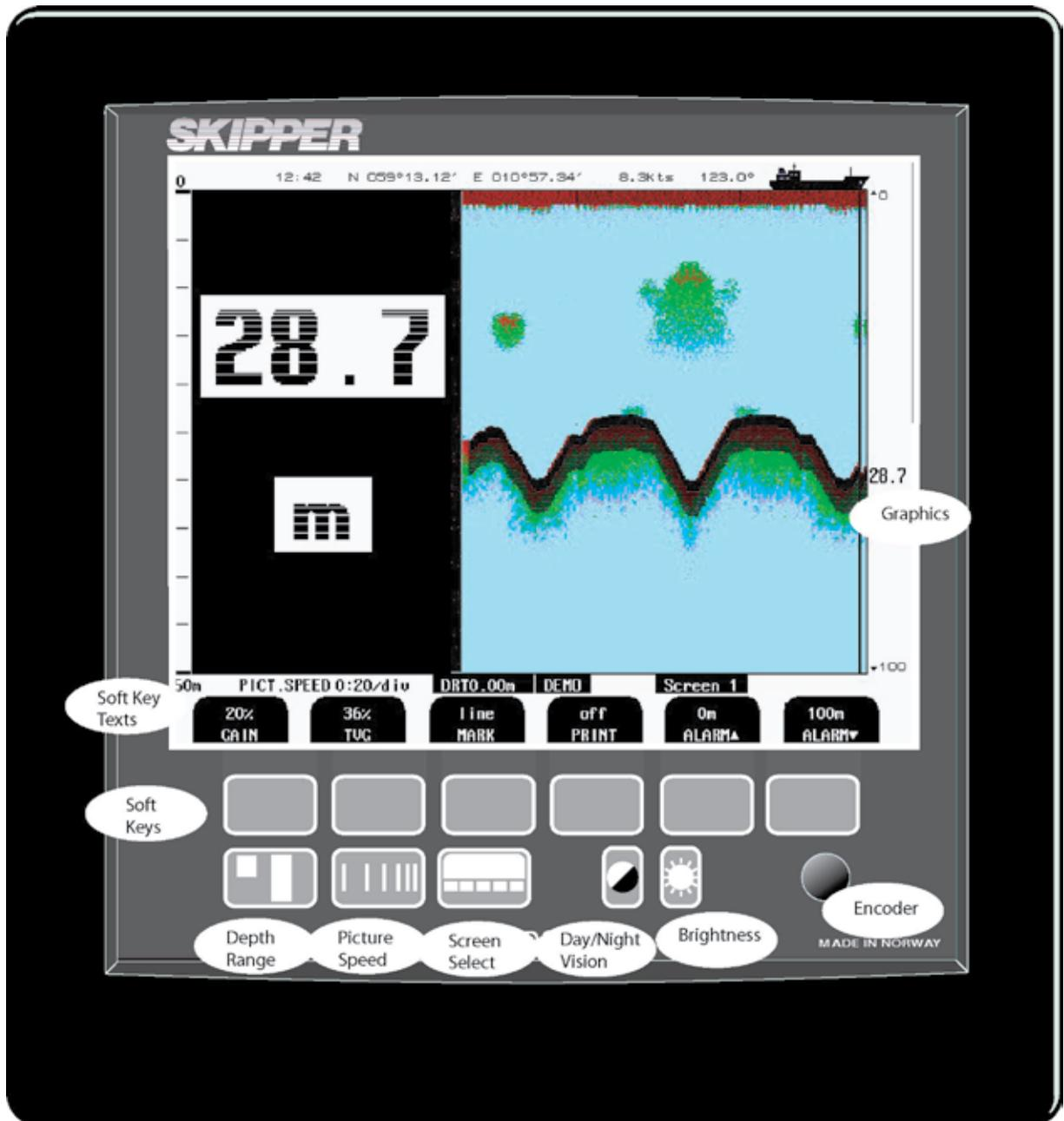

Fig. 1.1 Main Display Unit Panel Layout

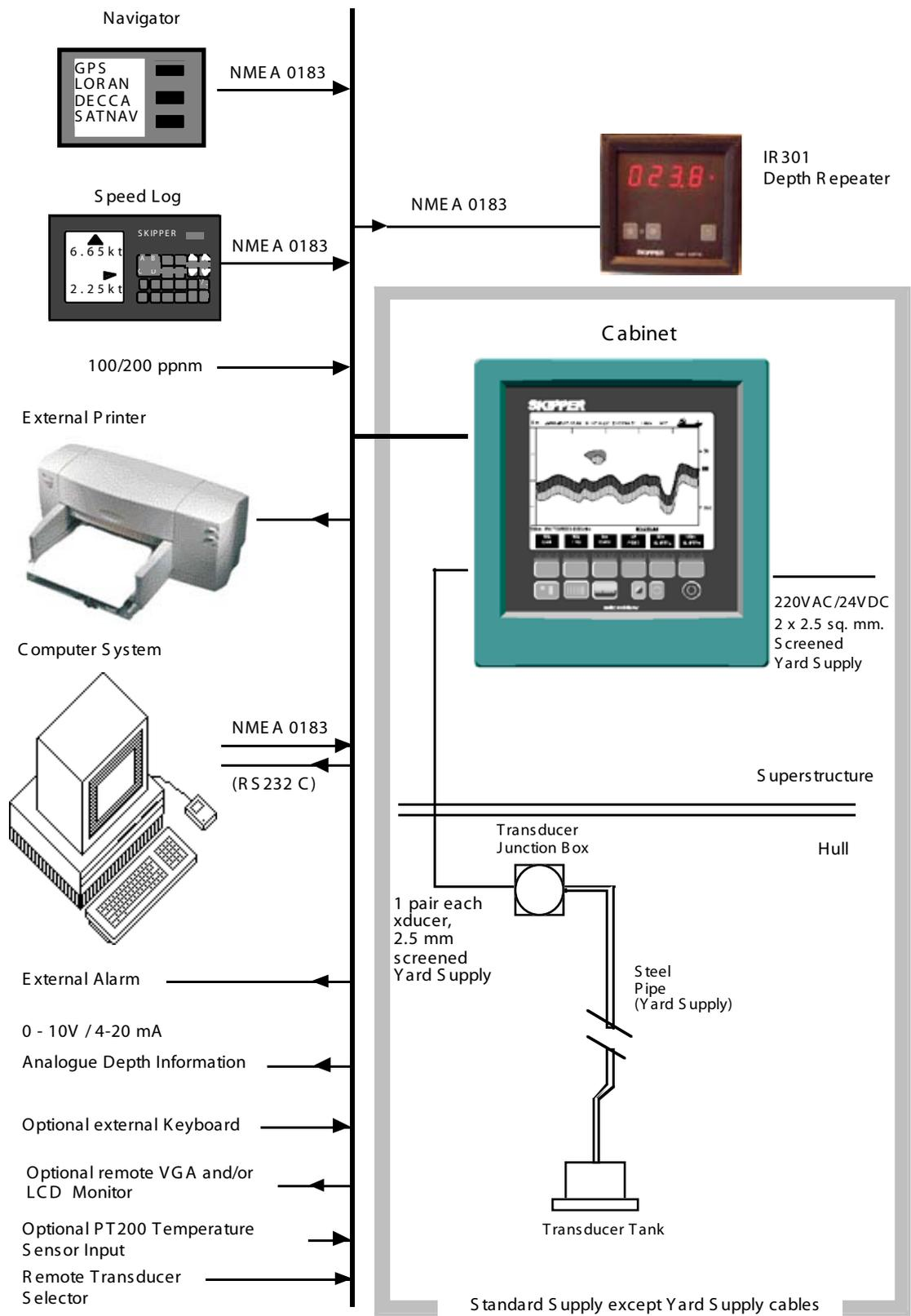

Fig. 1.2 System Diagram

## **INTERFACING.**

The GDS101 has various interface possibilities.

### **Outputs.**

Transmitter and Bottom Pulse Outputs.  
Analogue Output 0 - 10 V or 4 - 20 mA.  
NMEA0183 Interface Outputs of Depth Information.  
External Alarm Relay Output.  
External Printer.

### **Inputs**

Log Input 100/200 Pulses per nautical Mile.  
NMEA0183 Interface Input of Position, Heading, Speed, UTC.  
Remote Control and Synchronisation of Transmitter.(Option)  
Remote Transducer Switch

## **ALARMS.**

Shallow and deep alarms may be selected from Screen 1. A potential free relay contact is provided in GDS101 for interface to external alarm systems.

## **HISTORY MEMORY**

GDS101 has a 24 hour history memory. Depth, time and all available navigation data are stored continuously so that the last 24 hours of information is always available, and may be printed if an external printer is connected..

## **OPTIONS.**

### **Repeaters.**

Graphic CRT or LCD display or digital depth slave repeaters may be connected to the system. Along with the graphic display repeaters there may also be installed remote keyboards.

### **Remote Sounding Control.**

This option lets the GDS101 being controlled remotely in synchronised, burst or single ping modes.

### **Auto Range**

This option will automatically adjust the depth range to maintain the bottom contour within the middle half of the screen.

### **Sound Speed Calibration**

This option will enable adjustment of the sound speed value used for the depth calculations.

# GDS101 PRIMARY FUNCTIONS

0 m
15:03 GMT
N 13;13.20' E 079;44.5'
14kts
145j

# 80.0

# m

▲ 50

80

▼ 160

200m PICT.SPEED 0:08/div SCREEN 1

20%  
GAIN

25%  
TVG

line  
MARK

off  
PRINT

50m  
ALARM ▲

160m  
ALARM ▼

Gain Adjustment  
0% - 100%  
or Auto

TVG Adjustment  
0% - 100%

Print Marker  
or  
Screen Dump

Printer  
Start / Stop

Shallow  
Alarm  
Setting

Deep  
Alarm  
Setting

SCREEN 2

small  
DIGITAL

50kHz  
FREQ

line  
MARK

off  
PRINT

off  
SYSTEM

Large Depth  
Digits  
On / Off

Frequency  
Selection  
38 / 50 / 200 kHz

Print Marker  
or  
Screen Dump

Printer  
Start / Stop

System  
Off  
On = Any Key  
(Main Switches and  
Fuses inside Cabinet)

SCREEN 3

100%  
POWER

0.00m  
DRAUGHT

Power  
Adjustment  
10% - 100%

Draught  
Setting

Depth Range  
Setting.

Display Speed  
Setting

Menu Select Button  
Press the Menu Select  
Button repeatedly to cycle  
through the primary  
"Soft-Key" Screens

Day/Night  
Vision

Screen  
Backlight

Encoder Knob  
Rotate Encoder while  
keeping a Key pressed  
to change Setting  
or Menu

Soft-Key Legend on Screen 1

Soft-Key Legend on Screen 2

Soft-Key Legend on Screen 3

Soft-Key Function Buttons

Fixed-Key Functions

## 2. OPERATION

When the installation is complete, and power is connected to the Operator Unit, the system is switch one-off by power switch inside cabinet.

### PARAMETER ENTRY

The fixed function buttons and the soft key buttons of the various screens along with the rotating encoder, facilitates entry of parameters, setpoints and other data. The following flow chart illustrates the procedure for changing settings and entering data. The various screens are shown in detail in the Operation Section.

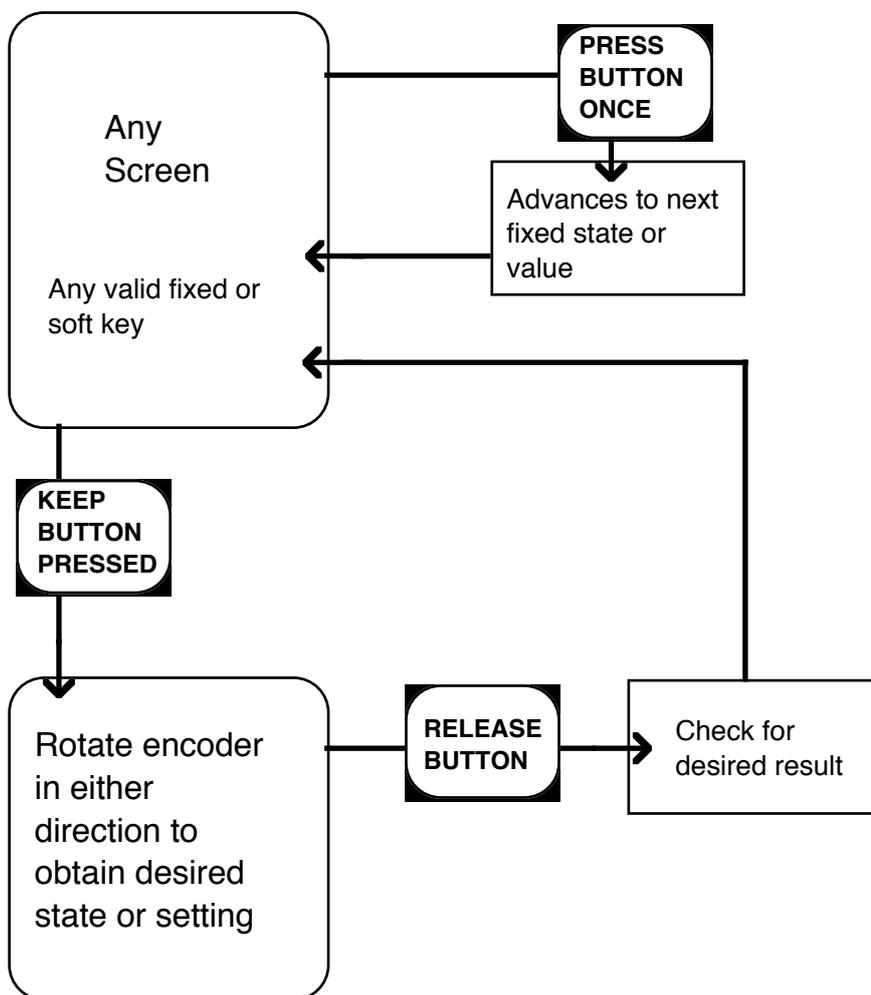

Fig. 2.1 Setting and Parameter Entry Flowchart

### Example of parameter entry.

Let us say you want to enter a value of **800 m** for the depth range.

Press the Depth Range button several times and observe the depth range sequencing through the standard values 10, 50, 100, 500, 1000 m. Press till the range is 500 m. Then press the Range button again and keep it pressed while you turn the encoder clockwise. Observe the depth range increase to 800 m, let go of the encoder and release the depth range button. You could also have started from the standard value 1000 m and decreased to 800 m by turning the encoder counter-clockwise.

Buttons with less than 6 possible states or values can be operated without using the encoder at all.

### OPERATION SCREENS

Each of the operation screens contains a graphic picture and a selection of up to 6 soft key buttons. The various screens are selected by keeping the “Menu” button pressed and rotating the encoder in either direction. Turning the encoder clockwise cycle the screens in the sequence 1 to 10, and counter clockwise rotation cycles the screens in the sequence 10 - 1. Screens no. 1 - 3, covering the primary functions, may also be cycled by repeatedly pressing the “Menu” button.

The screen layouts are outlined in Fig. 2.2 through 2.11. The various Soft Key button functions are described with each screen.

All Screens have 10 vertical subdivisions.

Primary operation Screens.

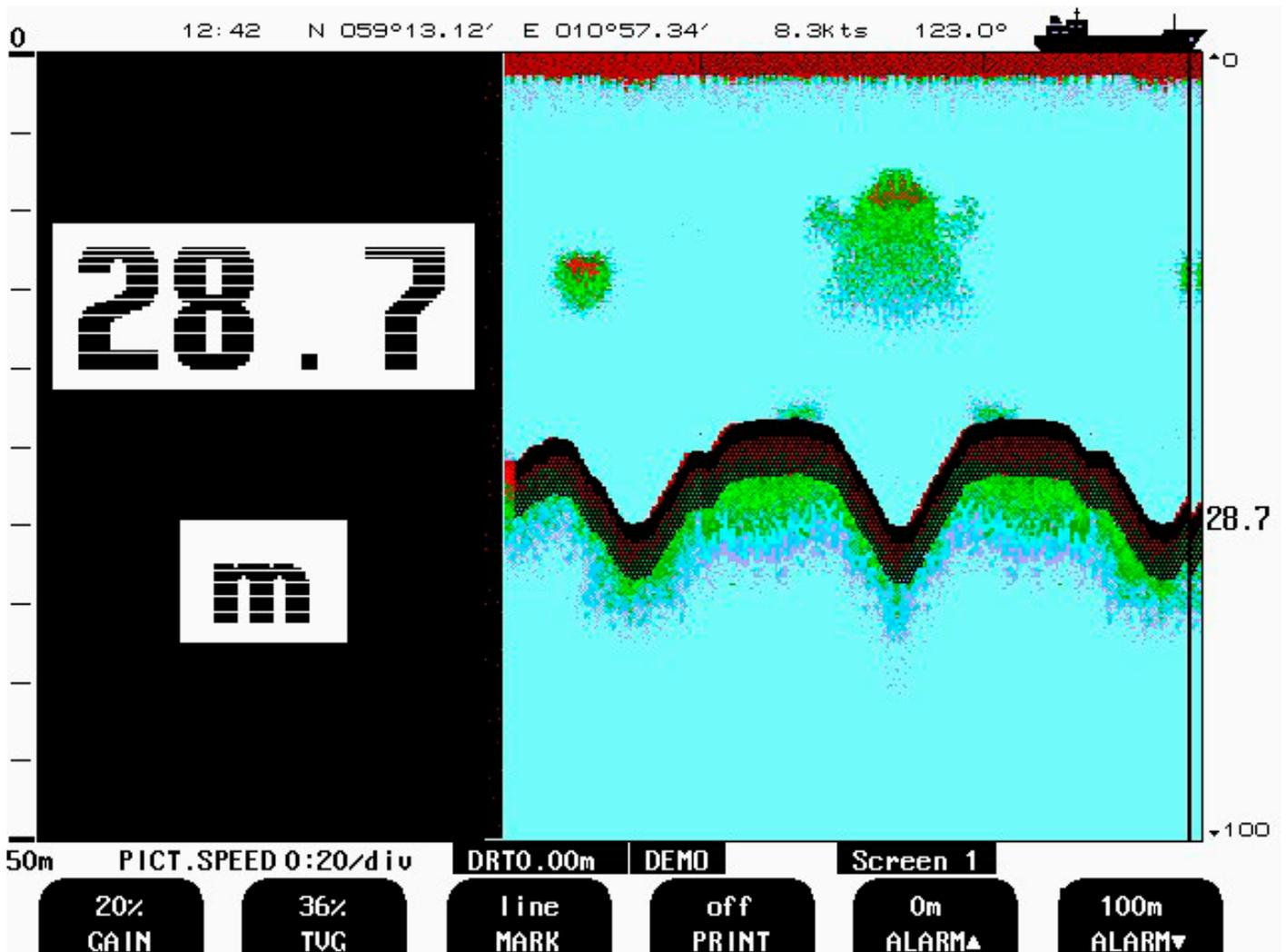

Fig. 2.2 Screen 1, Primary Operation screen.

This screen shows the main graphic echo-gram. Left hand digital indication may be enabled from screen 2.

Soft Key 1.	GAIN	0 - 100%	Gain Adjustment.(100% is max. Gain)
Soft Key 2	TVG	0 - 100%	Time Variable Gain Adjustment.(0% is max supression)
Soft Key 3	MARK	line	Suppression of echoes from 0-40meter
Soft Key 4	PRINT	on/off	Print mark line/Dump screen.
Soft Key 5	ALARM	0 - 100m	Start and stop of continuous printing. (If printer is switched off or not connected this button is "Dimmed")
Soft Key 6	ALARM	0 - 1600m	Shallow Alarm adjustment.
			Deep Alarm adjustment.

The currently selected Transducer ( Frequency ) is indicated at the bottom of all screens along with optional Transducer position, e.g. 200kHz/FWD. (DRT0.00m and 200kHz/FWD are switching 1 sec. interval.)

Selection of the Transducer Position Reference is performed in Screen 10.

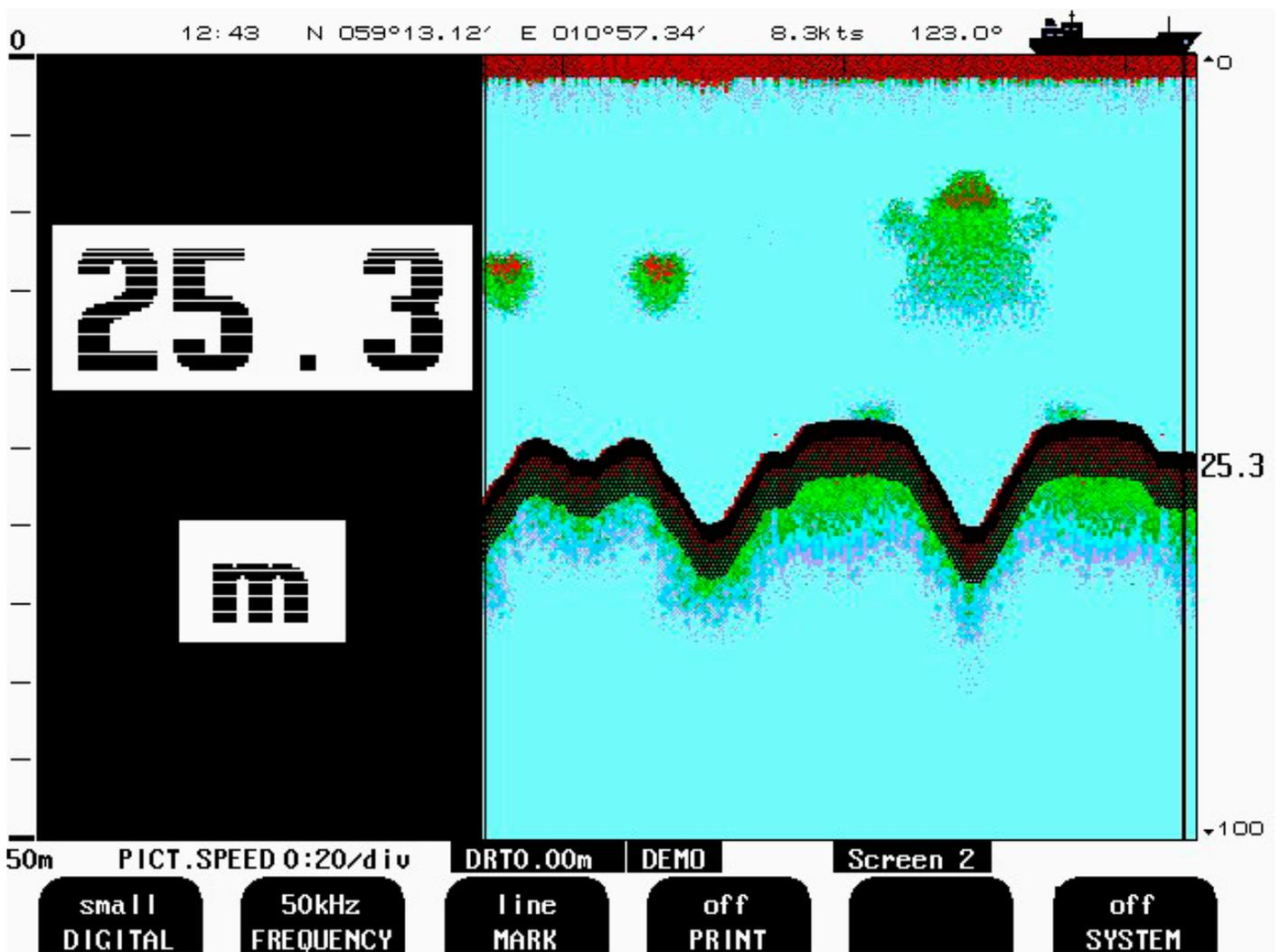

**Fig. 2.3**                    **Screen 2, 2nd Operation screen.**

This screen shows the main graphic echo-gram. Left hand digital indication may be enabled from screen 2.

Soft Key 1.	DIGITAL	off/small/large	Control of digital depth indication.
Soft Key 2	FREQUENCY	38/50/200	Transducer selection. (Have to be "Installed" in screen 10 soft key 2 and 3)
Soft Key 3	MARK	line	Print mark line/Dump screen.
Soft Key 4	PRINT	on/off	Start and stop of continuous printing.
Soft Key 5	not used.		
Soft Key 6	SYSTEM	off	Switch off System. Switch on with any button ( NOTE: Its still power on the GDS 101)

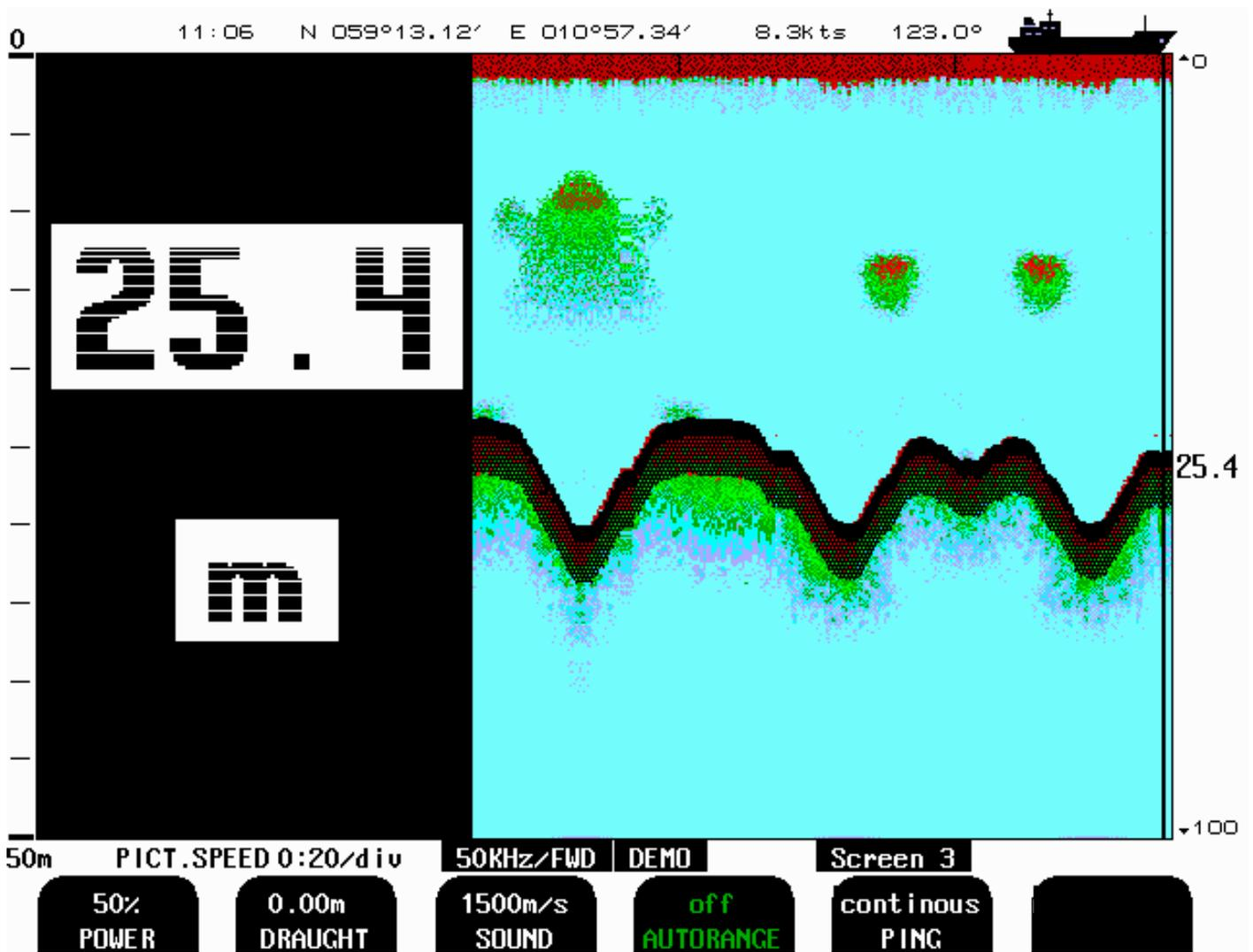

Fig. 2.4 Screen 3, 3rd Operation screen.

This screen shows the main graphic echo-gram. Left hand digital indication may be enabled from screen 2.

Soft Key 1.	POWER	0 - 100%	Transmitter power adjustment.
Soft Key 2	DRAUGHT	-100 to 100m	Draught correction, <u>must be set individually for each frequency.</u>
<i>Soft Key 3 option</i>	<i>SOUND</i>	<i>1400 - 1550m/s</i>	<i>Sound speed setting.</i>
<i>Soft Key 4 option</i>	<i>AUTORANGE</i>	<i>on/off</i>	<i>Auto Range control.</i>
<i>Soft Key 5 option</i>	<i>PING</i>	<i>continuous/single/edge</i>	<i>Ping control.</i>

*Note. Soft Keys 3 through 5 control optional functions.*

Secondary operation screens.

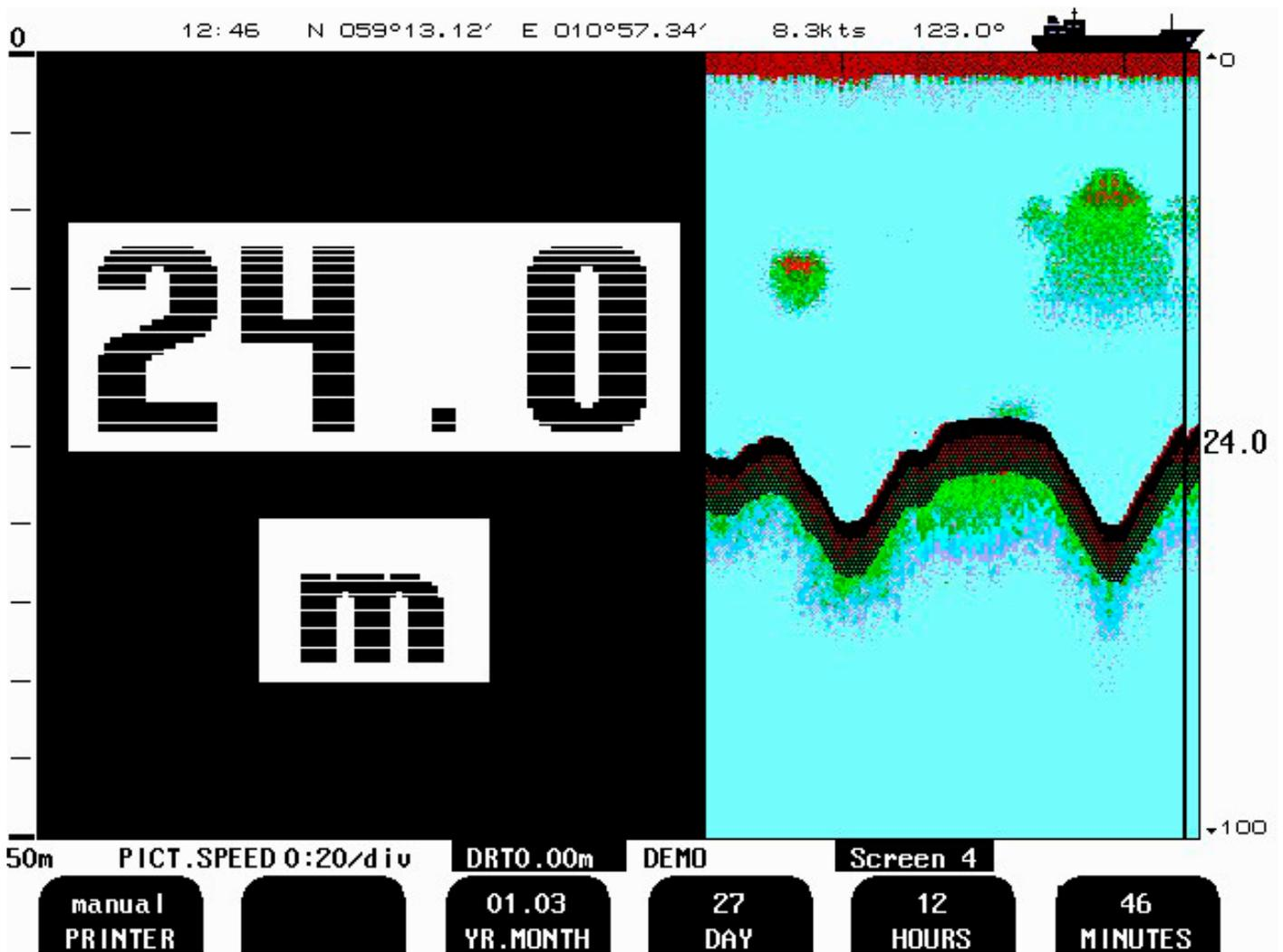
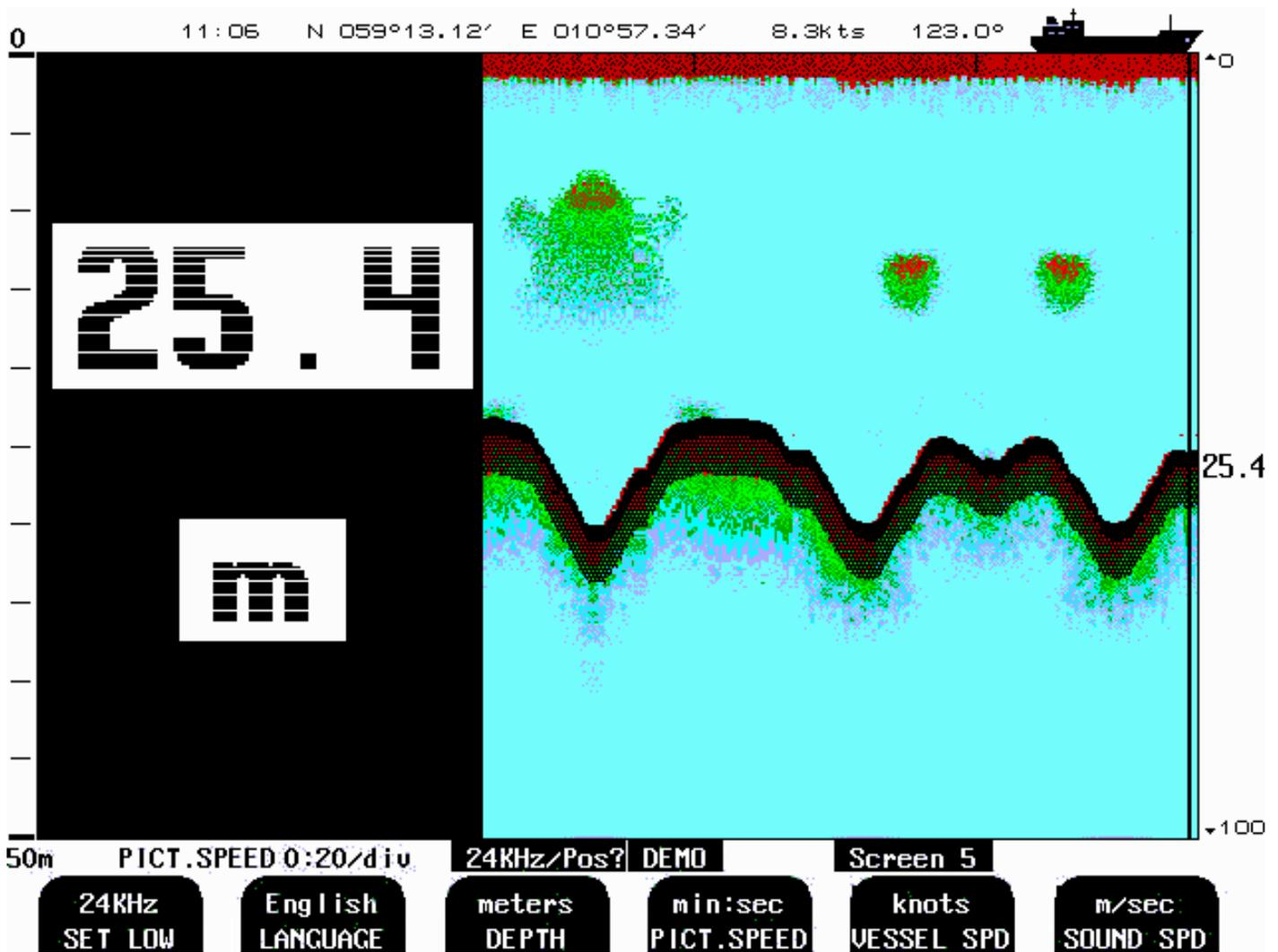

**Fig. 2.5** Screen 4, Calendar and clock setting.

This screen shows the main graphic echo-gram. Left hand digital indication may be enabled from screen 2.

Soft Key 1.	PRINTER	manual/auto auto	External Printer start options. Printer start, if depth alarm are activated.
Soft Key 2	not used		
Soft Key 3	YEAR.MONTH	01.03 ->	Calendar setting.
Soft Key 4	DAY	1 - 31	Calendar setting.
Soft Key 5	HOURS	0 - 23	Real time clock setting.
Soft Key 6	MINUTES	0 - 59	Real time clock setting.

Note : If GPS is connected soft key 3 to 6 are controlled by GPS



**Fig. 2.6 Screen 5, Language and units of measure Setup.**

This screen shows the main graphic echo-gram. Left hand digital indication may be enabled from screen 2.

Soft Key 1.	SET LOW	24/28/30/33/38KHz	Adjust indicated frequency of lower frequency channel. (see chapter 5. <b>Low frequency indication</b> )
Soft Key 2	LANGUAGE	English etc.	Screen language selection.
Soft Key 3	DEPTH	m etc.	Unit of measurement for depth.
Soft Key 4	PICT.SPEED	m:s/div etc.	Unit of measurement for picture speed.
Soft Key 5	VESSEL SPEED	knots etc.	Unit of measurement for vessel speed.
Soft Key 6	SOUND SPEED	m/s etc.	Unit of measurement for sound speed.

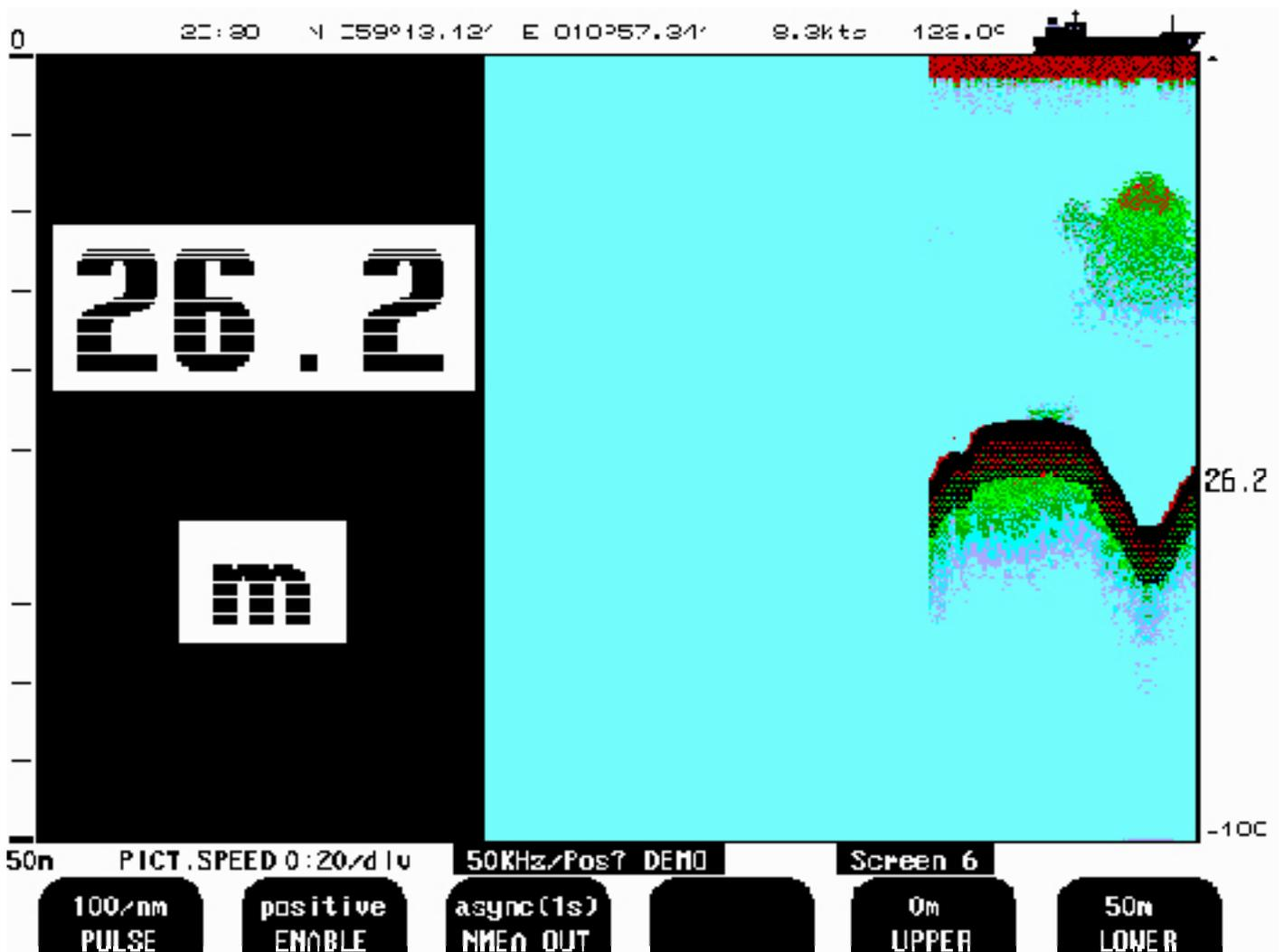

**Fig. 2.7**                    **Screen 6, Interface Setup screen.**

This screen shows the main graphic echo-gram. Left hand digital indication may be enabled from screen 2.

Soft Key 1.	PULSE	100/200/400/20000	Log pulse input calibration.
Soft Key 2	ENABLE	pos/neg	select polarity of external sync signal (remote sounding control option)
Soft Key 3	NMEA OUT	async(1s)/ synchronous	Select between synchronous (with sampling rate) and asynchronous (1s period) NMEA output update.
Soft Key 4	not used		
Soft Key 5	UPPER	0 - 98m	Analogue output shallow limit = 0V.
Soft Key 6	LOWER	0 - 99m	Analogue output deep limit = 10V.

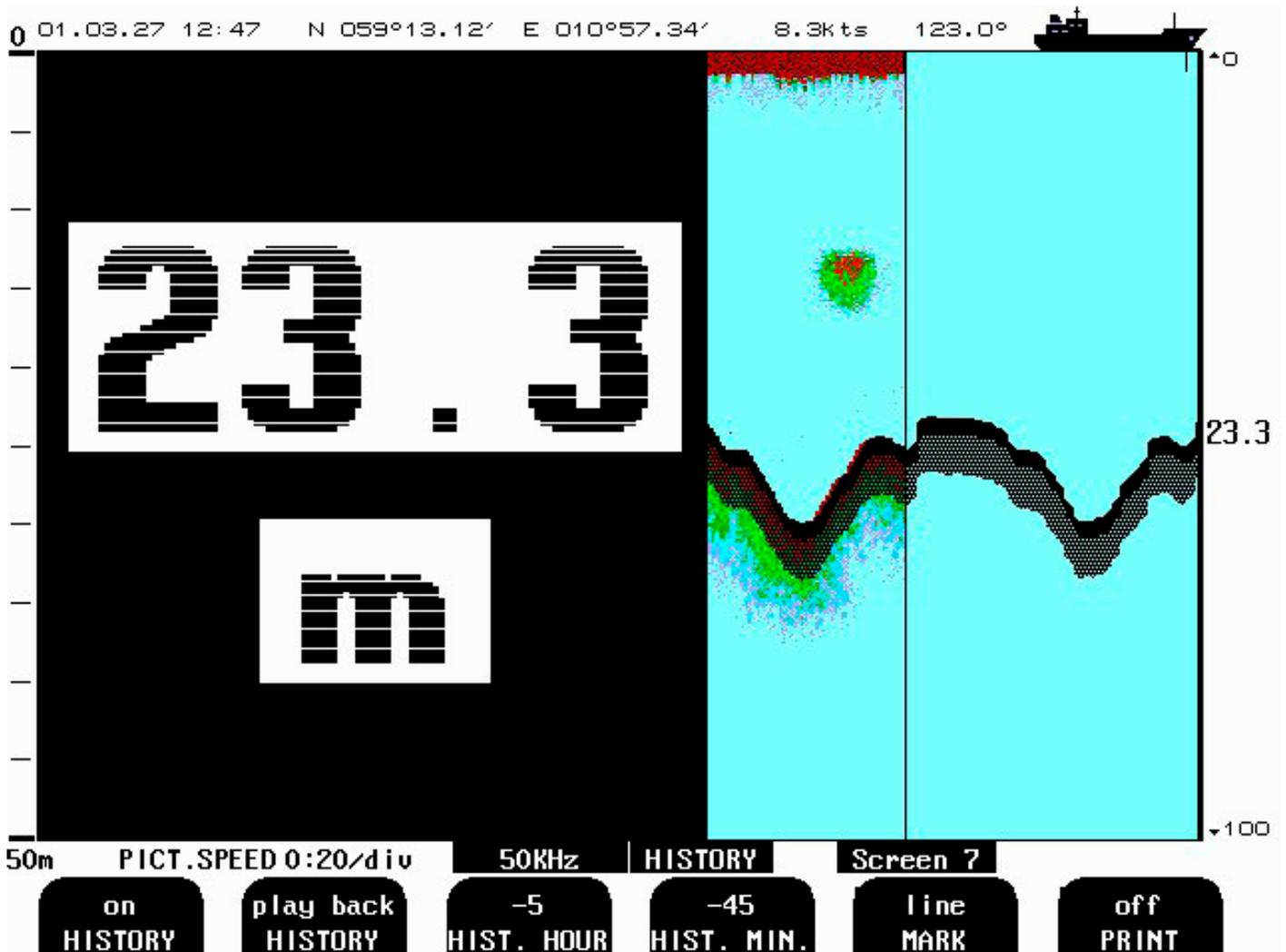

**Fig. 2.8**                    **Screen 7, History Memory Control Screen.**

This screen shows the main graphic echo-gram. Left hand digital indication may be enabled from screen 2.

Soft Key 1.	HISTORY	on/off	Start/stop(keep) History Recording.
Soft Key 2	HISTORY	Record/Playback	Record/Playback of History.
Soft Key 3	HIST.HOUR	-24 - 0 hour	History Playback Spooling, hours.
Soft Key 4	HIST.MIN	-59 - 0 min	History Playback Spooling, minutes.
Soft Key 5	MARK	line	Print mark line/Dump screen.
Soft Key 6	PRINT	on/off	Start and stop of continuous printing.

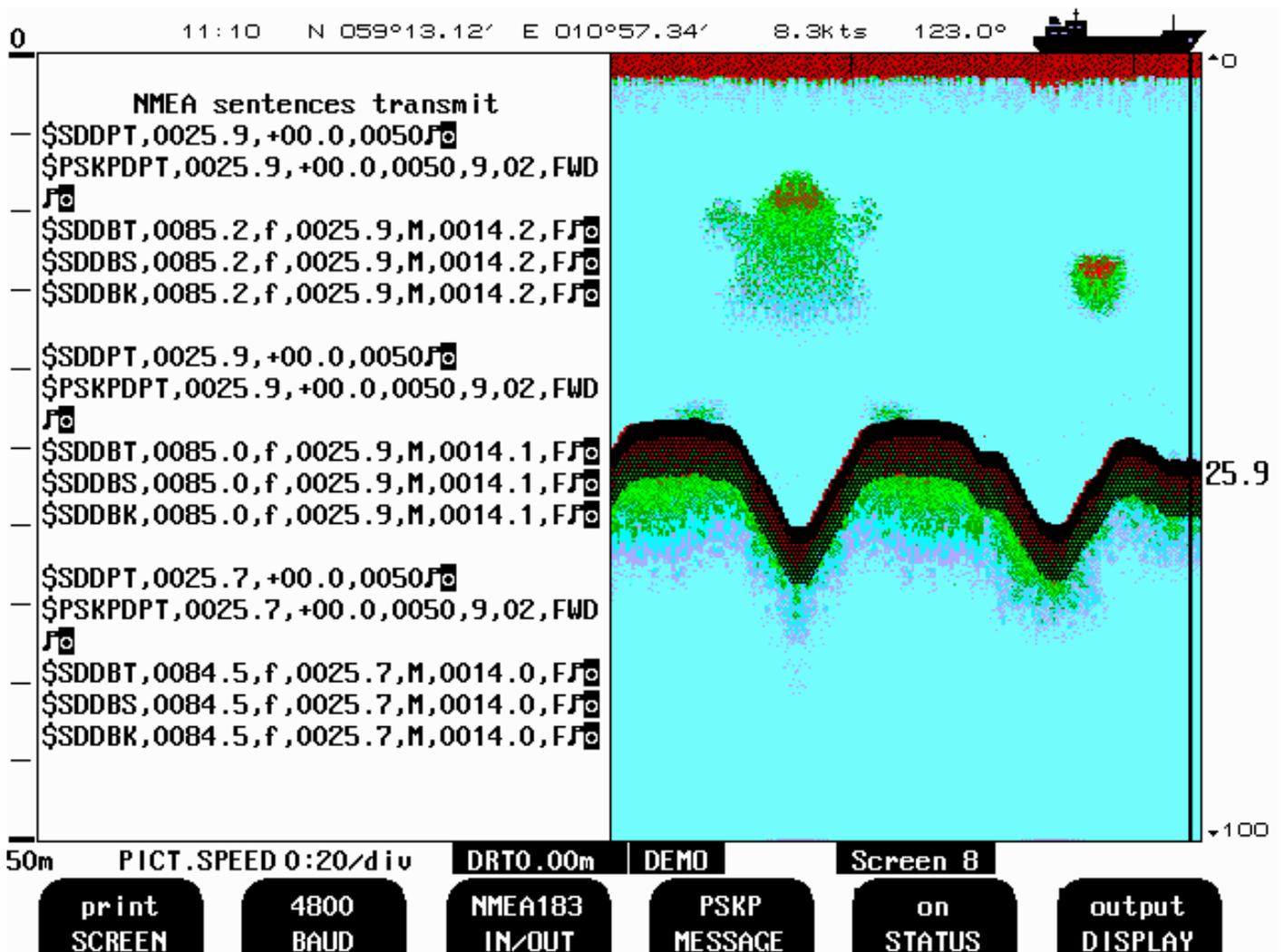

**Fig. 2.9** Screen 8, NMEA Control Screen.

This screen shows list of received NMEA messages and half screen echo-gram.

Soft Key 1.	PRINT	screen	Print Screen.
Soft Key 2	BAUD	4800/9600	NMEA Baud Rate Selection
Soft Key 3	IN/OUT	NMEA0183/RS232	I/O Port Selection
Soft Key 4	MESSAGE	DPT/DBS/DBT/DBK/XDR EN250/PSKPDPT	Select if message should be on/off by soft key5.
		CHECK SUM	Select if PSKPDPT should contain check sum or not by soft key5.
Soft Key 5	STATUS	on/off	Select if enabled Message by soft key 4 should have on or off status.
Soft Key 6	DISPLAY	off/input/output	Message display Operation.

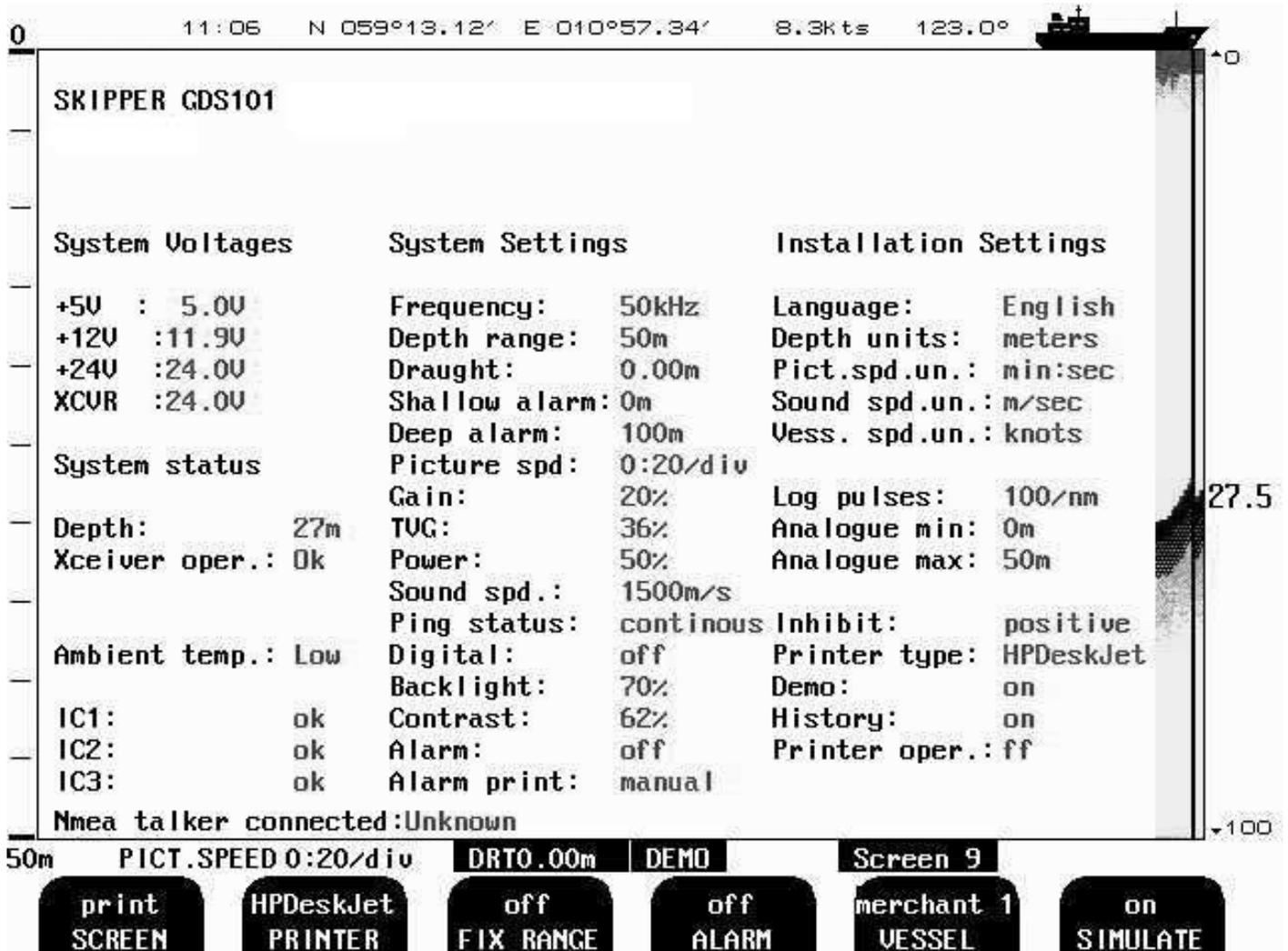

**Fig. 2.10** Screen 9, System Status Screen.

This screen shows a comprehensive list of system settings and parameters.

Soft Key 1.	PRINT	screen	Print screen.
Soft Key 2	PRINTER	HP DeskJet / Epson (Lq300+) / Epson D88 / Built-in thermal printer.	Select type off printer that are connected.
Soft Key 3	FIX RANGE	on/off	Limit Search Range to Window <b>on FIX RANGE</b> gives better detection in case of noisy signal.
Soft Key 4	ALARM	on/off	Internal Alarm Buzzer Control.
Soft Key 5	VESSEL	merchant1/2, Navy1/2	Upper right Screen Icon Selection.
Soft Key 6	SIMULATE	on/off	Built-in Simulator Control.

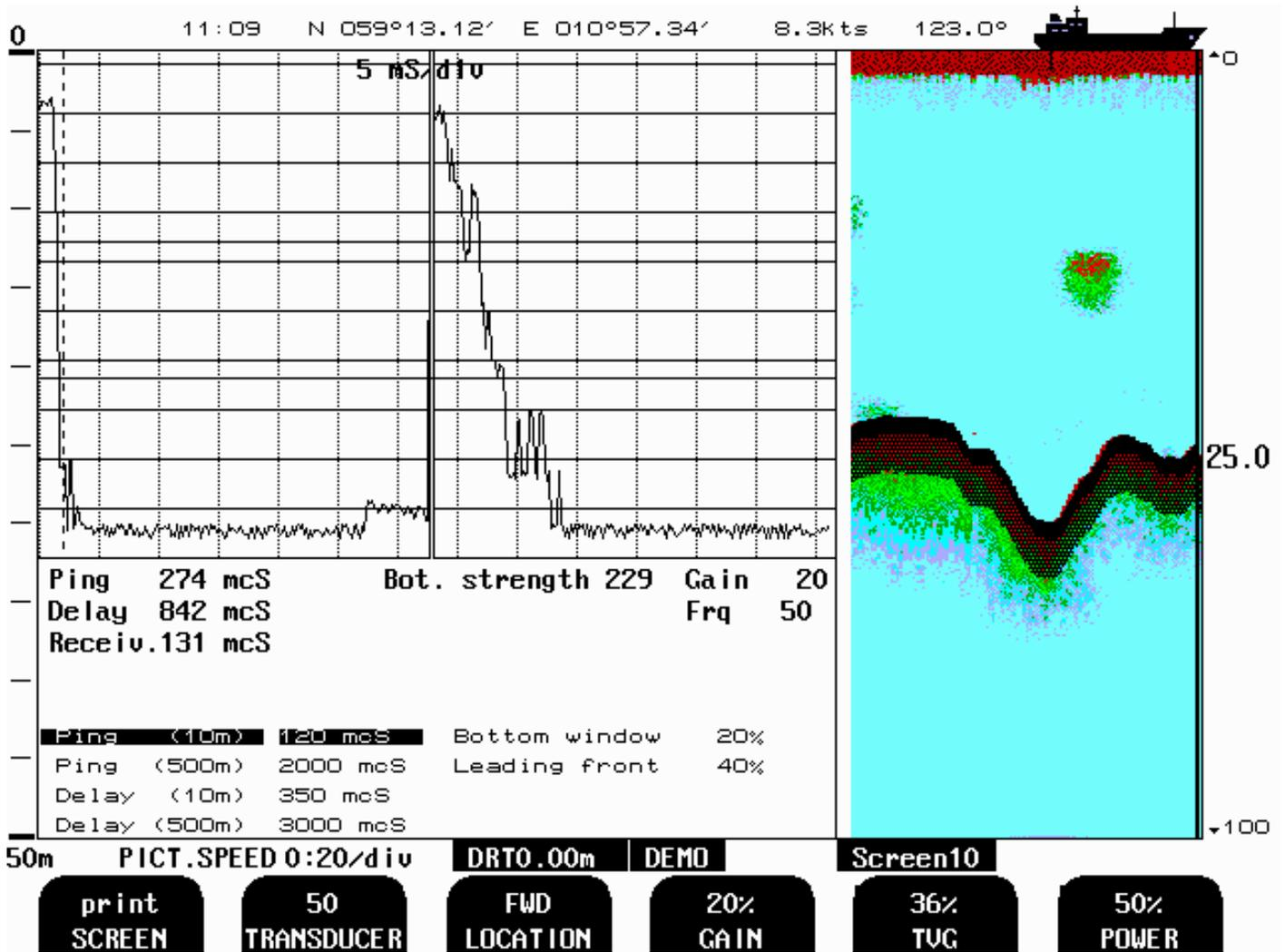

**Fig. 2.11 Screen 10, Oscilloscope Screen.**

This screen shows oscillator program of receiver output versus time and half screen echo-gram.

Soft Key 1.	PRINT	screen	Print screen.
Soft Key 2	TRANSDUCER	200, 50, 38	Transducer selection for Soft key 3
Soft Key 3	LOCATION	Pos?,not installed,	(Pos? is default setting) If "NOT installed" is selected for one of the Frequences it will not be available in screen 2,soft key 2.
		Fwd, Aft, Port, Strb	To select position of transducer
		Fwd/Aft, Port/Strb	2 Transducers with Transducer selector (ENS518) See page 52 Remote Transducer selector See page 53 for Nmea sentence
Soft Key 4.	GAIN	0 - 100%	Gain Adjustment.
Soft Key 5	TVG	0 - 100%	Time Variable Gain Adjustment.
Soft Key 6	POWER	0 - 100%	Transmitter power adjustment.

## PRINCIPAL FUNCTIONS

### **Bottom detection**

GDS101 employ a bottom detection algorithm that will try to extract the bottom signal from all kinds of noise and secondary echoes. When GDS101 is tracking the bottom normally, a thick black line is shown, and below that, a ribbon with a hatched pattern. This pattern has two levels of hatching. The darkest represent strong and unambiguous bottom echoes. The lighter hatching represents weaker signals possibly occasional detection misses. If the software can detect no bottom for several pings, the hatched ribbon disappears.

During normal bottom tracking, a digital value is shown by the bottom contour at the right side of the screen. If the software algorithm losses track of the bottom altogether, a warning beep is heard and the black line and hatching band disappears. A warning message: “Lost bottom” is shown in the screen’s lower right corner.

### **Ping to Ping filtering**

Part of the bottom detection algorithm is the ping to ping filtering. The next bottom is searched for in a time and strength window based on the strength and timing of the previous bottom echoes. This procedure reduces the probability of tracking schools of fish or secondary echoes as bottom.

If no bottom is detected in the calculated window, the window is gradually increased in size until the full time and strength window is used.

### **Bottom Search Range**

The FIX RANGE function in Screen 9 is used to control the search range for the bottom detection algorithm. When this function is on, bottom is only searched for within the selected display range. When the function is off, bottom is searched for within the entire functional range of the echo sounder.

### **Power ON/OFF**

During normal daily operation, the system may be switched off from Screen 2. This operation does not disconnect the system from the power supply, but all power consuming components are switched off. The system may be switched on again by pressing any button.

Do not run the sounder for a long time without a submerged transducer connected.

### **Alarm acknowledgement.**

When the depth alarm is activated, the alarm may be acknowledged by pressing any button.

## FIXED KEY FUNCTIONS.

### Depth Range

The Depth Range button can be used to set the depth limit between 10 and 1600 m. Standard values available by repeatedly pressing the button are 10, 50, 100, 500 and 1000m.

### Picture Speed

Picture speed may be referred to either time or Vessel speed. If no speed log is connected, Picture Speed will always be referred to time. (“mm:ss/div”).

Time referenced Picture Speed may be selected between 20 Seconds per division and 5 minutes per division.

Vessel Speed referenced Picture Speed may be selected between 0.04 nm per division and 5 nm per division.

If a speed log is connected, it is possible to select a “speed/div” unit in Screen 5.

The ping-rate range depends on the Depth Range, and the fastest ping rate at shallow depths is about 5 pings per second.

### Menu

The menu button facilitates selection of one of the 10 screen and soft key layouts. The 3 primary operation screens may be cycled by repeatedly pressing the MENU button. Access to the remaining screens is through encoder operation. The screens are cycled in an endless, bi-directional loop, e.g. turning the encoder counter-clockwise, will activate Screen 10 after Screen 1.

Turning the encoder with no buttons pressed always force Screen 1.

### Day / Night & Back light adjustment

Back light may be continuously controlled by means of the appropriate buttons and the encoder. Press either button and rotate the encoder until a satisfactory setting is obtained, then release the button.

Day / Night vision see chapter 1. INTRODUCTION System Summary for Color bar explanation.

Day / Night vision may be changes by means of pressing the Day / Night Button. ( see fig. 1.1 )

The settings are maintained in the non-volatile memory, and the last settings are restored on power up.

It is also possible to cycle through 3 standard backlight / picture settings by repeatedly pressing the brightness button. The 3 settings are:

- |    |         |                             |
|----|---------|-----------------------------|
| 1. | Minimum | backlight, Day/Night vision |
| 2. | Half    | backlight, Day/Night vision |
| 3. | Maximum | backlight, Day/Night vision |

## SOFT KEY FUNCTIONS.

### Gain

**Gain** may be adjusted from 0 to 100% to allow for optimal echo levels from bottom and other objects. The GAIN setting affects signals from all depths.

### TVG

Time Variable **Gain** may be adjusted from 0 to 100 % to allow for detailed echo control from the 0 - 50 m depth range.

A low setting will reduce the gain in the area near the surface to suppress noise and unwanted echoes from this area.

### Digital indication

On the operation screens, two sizes of large digital depth indicators may be selected from Screen2.

“Small” digits occupy approximately 40% of the net echo-gram screen width.

“Large” digits occupy approximately 55% of the net echo-gram screen width.

### Frequency

The Frequency selector toggles among 38, 50 and 200 kHz.

### Output Power

Power may be adjusted from 10 to 100 % in case of difficult shallow water conditions. Too high power in such cases will possibly saturate the receiver or cause detection of unwanted secondary bottom or surface echoes.

When a range of 10m is selected, Output Power is automatically limited to 10%.

### Draught

Draught may be compensated to allow real depth from surface to be shown on the screen and printout.

Negative draught values may be entered to compensate for transducers fitted above the keel.

This setting also affects the NMEA transmitted values.

Draught compensation is indicated on the screen by a flashing number to alert the operator to the fact that the shown depth value is adjusted.

### External Printer Operation

The optional external printer is started and stopped by the **Print** buttons. The printer may be used for continuous printing over a period of time or the current screen contents may be dumped to the printer for reference if something interesting is observed.

The **Print** buttons switch continuous printing on and off.

The **Mark** buttons will write a line mark on the paper if it is pressed whenever the printer is running.

If the **Mark** button is pressed when the printer is off, this will initiate a screen dump of the present screen contents.

If printer is switched off, or Not connected print button is “Dimmed”.

## **Alarm settings**

Depth alarm settings are performed from Screen 1. Alarm limits are referred to the indicated depth. The local alarm buzzer may be disabled from screen 9, but the external alarm relay will always operate. The only way to disable the alarms completely, is to reduce the shallow alarm to zero depth and increase the deep alarm to maximum range.

An active shallow alarm limit must be less than an active deep alarm limit. Alarm limits are enforced with hysteresis.

A depth alarm may automatically start the optional printer if this function is enabled on Screen 4.

## **Clock and Calendar Settings**

Manual Clock and Calendar adjustments are carried out in Screen 4. If a Satellite navigator giving UTC messages is connected to the NMEA input, the clock and calendar will be automatically updated and manual adjustment is not required.

## **History Memory**

GDS101 has a 24 hour history memory. Depth, time and all available navigation data are stored continuously so that the last 24 hours of information is always available.

The history memory is controlled from Screen 7.

The normal history modes are “on” and “recording”. New depth information is continuously stored in the memory while the oldest samples are discarded. Only bottom information is stored along with time and whatever navigational information is available in the GDS101 (Position, Speed, Heading).

By switching history “off”, the stored 24 hours will be kept in the memory and no new samples will be written. As a warning that the memory is not recording, “History off” is flashing at the bottom of the screen.

History modes “on” and “playback” will start playing the contents of the history memory on the screen and on the optional printer if it is running. As a warning that the displayed bottom contour is from the memory and not real time, “History” is flashing at the bottom of the screen.

The “history hours” and “history minutes” buttons used with the encoder, will enable positioning within the 24 hour memory to observe the desired part of the time frame during playback.

### **Simulator**

The GDS101 contains a built in simulator to exercise the screen and various interface signals. The simulator may be switched on and off on Screen 9.

When the simulator is operating, “Demo” is flashing at the bottom of the screen.

### **Status Screen**

The Status screen, Screen 9 shows a list of various system parameters useful for documenting system set-up and system operating status. The contents of this screen will be valuable information in situations where manufacturer support is required.

### **Oscilloscope Screen**

The Oscilloscope screen, Screen10 is useful when monitoring transceiver performance. The oscillogram shows the signal returned from the transceiver plotted against time and will enable service personnel to evaluate system performance and facilitate any troubleshooting.

### **Non-volatile Parameter Memory.**

The system contains internal flash memory to maintain installation and user parameters like Language and unit of measurement selection, Contrast and Backlight settings, etc.

These parameters are automatically restored on power up. If the user parameters have never been set, default values are used.

## OPTIONS.

### **Repeaters/Slaves**

Graphic display or digital depth slave repeaters may be connected to the system. Along with the graphic display repeaters there may also be installed remote keyboards.

### **Remote Sounding Control.**

This option lets the GDS101 being controlled remotely in synchronised, burst or single ping modes. If installed, this option is accessible on Screen 3.

### **Auto Range**

This option will automatically adjust the depth range to maintain the bottom contour within the middle half of the screen height. If installed, this option is accessible on Screen 3.

When the optional printer is started, Auto Range is automatically disabled, and the present depth range is selected as fixed.

### **Sound speed calibration**

This option will enable adjustment of the sound speed value used for the depth calculations. The standard value is 1500 m/s, but the user may set values from 1400 to 1550 m/s to accommodate accurate propagation speed in known water conditions. If installed, this option is accessible on Screen 3.

### **External Printer**

**Printer for endless paper or inkjet printer for single sheets ( ask for actual type) may be connected for hardcopy requirements.**

### **3. USER MAINTENANCE**

#### **TRANSDUCER MAINTENANCE.**

The transducers are virtually maintenance free, but occasional cleaning may be necessary depending on sea water conditions.

#### **OPERATOR UNIT MAINTENANCE.**

The operator unit contains no user serviceable parts, and requires no maintenance apart from occasional cleaning of the front panel. Please use a soft cloth and no chemicals except cleaning alcohol.

## Trouble Shooting

Symptom	Cause	Remedy
<b>Basic System Integrity</b>		
No Picture on LCD Screen	<p>No AC or DC power to the system</p> <p>System is in Standby</p> <p>To low Screen backlight</p> <p>Defective LCD module or Interface</p> <p>Voltage(s) out of Range</p>	<p>Check Switches and Fuses on the Terminal Board inside the GDS101 Cabinet.</p> <p>Press any Button on Panel</p> <p>Increase backlight Setting, Change to Day Vision</p> <p>Replace Module or Interface PCB</p> <p>Replace Terminal PCB</p>
Picture is difficult to read	<p>Backlight is too weak</p> <p>Night vision is on during day time.</p>	<p>Increase Backlight Setting</p> <p>Increase Backlight Setting, Ore change to day vision</p>
Display Backlight malfunctions, Display picture is visible	<p>Defective Backlight tubes</p> <p>Defective Backlight power inverter</p>	<p>Replace Tube Assembly</p> <p>Replace Keyboard PCB</p>
Rotary Encoder malfunctions	Defective Encoder or interface	Replace Keyboard PCB or Interface PCB
Panel Buttons malfunction	<p>Defective Buttons or interface</p> <p>One button stuck</p>	<p>Replace Keyboard PCB or Interface PCB</p> <p>Check Key Switches or Replace Keyboard PCB</p>

TYPICAL STATUS SCREEN (9) CONTENTS.

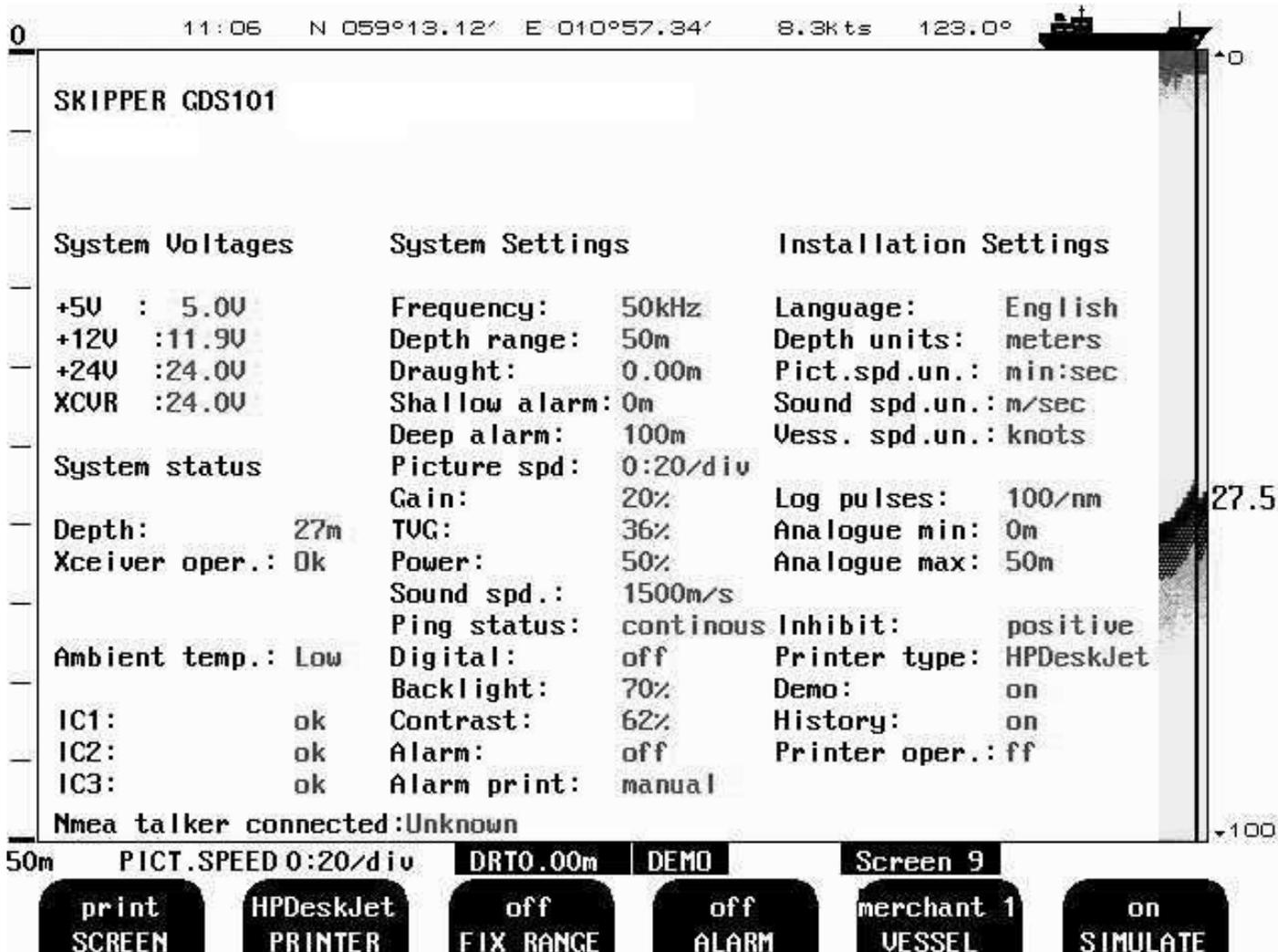

The status Screen (9) contain information that will facilitate analysis and correction of several problems. A printout of the Status and Oscilloscope Screens should be sent by fax with any report about functional Disturbance. This will greatly facilitate remote failure Analysis.

If it is at all possible to cycle through the screens and observe this information, several assumptions may be made regarding operation of the GDS101 System. Although some of the subsystems necessary for this basic system operation may still suffer from minor or intermittent operation disorders, the fact that it is possible to select and observe this screen, indicate correct operation of the following GDS101 Subsystems:

1. The Computer is operating.
2. The Screen Interface (VGA) Board is working.
3. The Keyboard interface Board with Backlight and LCD power supplies is working.
4. The Keyboard Interface Part of the I/O Board is working.
5. The Power Supplies on the terminal board are basically working.

Symptom	Cause	Remedy
<b>Status Screen Diagnosis</b>		
Main Voltages out of Range +5V: 4.7V - 5.3V +12V: 11.3V - 12.7V +24V: 22.5V - 25.5V BW VERSION + 12V <sub>INV</sub> : 11.3V - 12.7V COLOUR VERSION	Defective Power Supply  Power Supply Overload	Replace Terminal Board.  +5V: Computer or I/O Board Problem. +12V: Transceiver Problem. +24V: Screen Backlight Problem
Transceiver (XCVR) Voltage low	Power Setting to low  Defective Power Supply	Increase Power Setting  Replace Terminal Board or I/O Board.

The other information on the Status screen is a collection of information which may be observed and manipulated with the various screen softkey selections. As a reference, it will often be more convenient to observe the various settings together on this screen than to cycle from screen to screen to check on the softkey texts.

TYPICAL OSCILLOSCOPE SCREEN (10) CONTENTS.

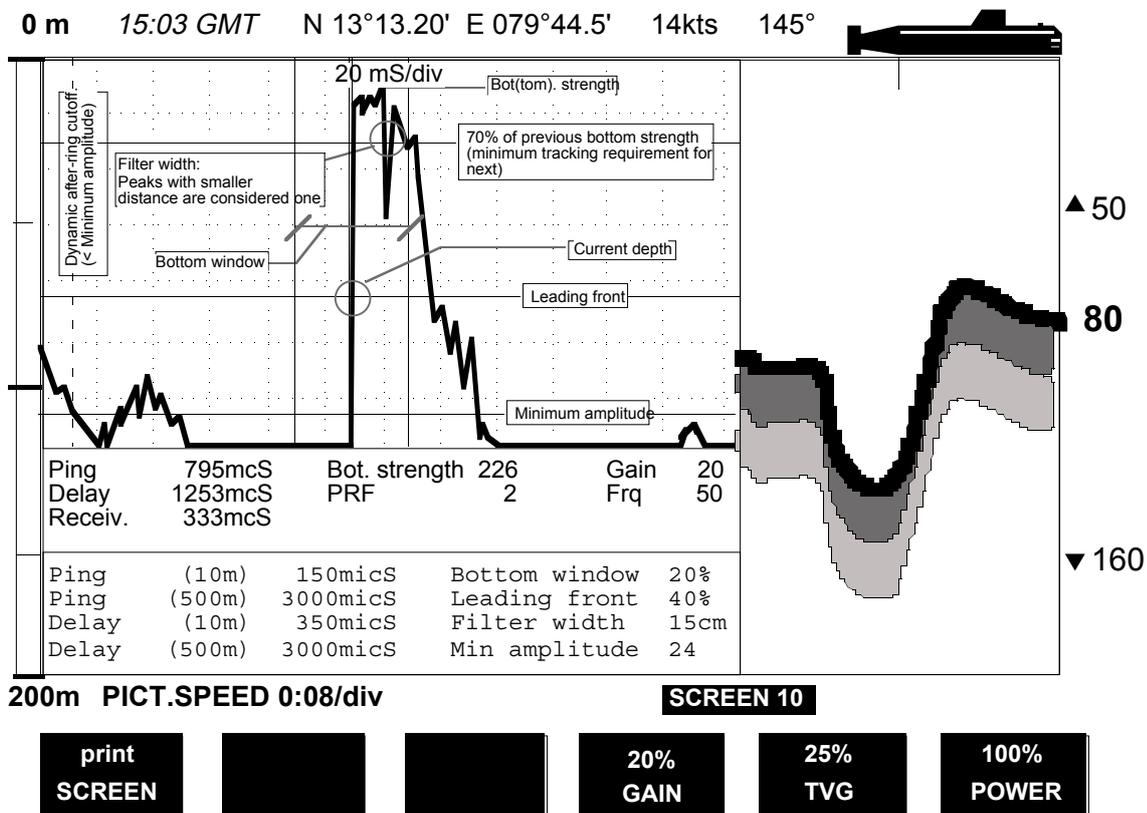

This Oscilloscope Screen (10) shows a typical oscillogram of a bottom echo (the tall peak in the centre of the diagram) and a weaker fish echo to the left of it. The horizontal axis represent time for the sound to travel down and back from an object. The vessel is located at the left edge of the grid, and the right edge represent the deep range. The vertical axis represent the magnitude of the echo signal received.

<b>Symptom</b>	<b>Cause</b>	<b>Remedy</b>
<b>Basic Functionality</b>		
No Bottom Detection or Bottom Contour	Too low Gain Setting Too low TVG Setting Too low Power Setting Wrong Frequency Selection	Adjust Settings Select correct frequency
Bottom tracking is intermittent or erroneous	Marginal Gain, TVG or Power Settings Weather Conditions Transducer installation faulty	Adjust settings Try adjusting Gain, TVG or Power Settings. Check transducer wiring, Receiver LED on interface Board or Oscilloscope Screen.
Bottom tracking is masked by high noise levels	Too high Gain Setting Too high TVG setting To high Power Setting	Adjust settings

<b>Symptom</b>	<b>Cause</b>	<b>Remedy</b>
<b>NMEA Interface etc.</b>		
NMEA input signals are not listed in the NMEA Screen (8).	Wrong Polarity input Signals	Swap NMEA0183 Input wires
NMEA input signals are listed in the NMEA Screen (8), but not accepted by the GDS101	GDS101 Initialisation  Irregular Message Mnemonic	Cycle GDS101 power after NMEA Connection is established.  Check Remote (Talker) Setup.
NMEA output signals are not accepted by the remote system	Remote (Listener) Setup	Verify correct Remote (Listener) Setup.
Analogue output malfunctions.	Incorrect Range Setting.	Verify upper & lower Limits in Screen 6.
Pulse output malfunctions	Incorrect Pulse Frequency Setting.	Verify Pulse Setting in Screen 6.
External Control Inputs malfunction, Inhibit/External Printer Control	Incorrect Polarity or Function Settings	Verify Settings in Screen 6.

## 4. INSTALLATION

### STANDARD SYSTEM SUPPLY.

A Basic GDS101 system consists of the following units. See **Fig. 4.1**:

Pos.	Description
1	Operator Unit with installation material
2	Transducer Junction Box(es)
3	Approved transducer steel tank(s)
4	Transducer(s) with attached cable(s) and installation material
5	Operation and Installation Manual

### TRANSDUCER INSTALLATION.

#### Location.

Single transducers are normally installed in the foreship. Larger vessels are often fitted with two transducers, one fore and one aft.

Optimal system operation is achieved by fitting the transducer as deep as possible on the hull. The transmitting surface of the transducer must be installed horizontal. On vessels with a deep keel, if the transducer must be fitted higher than the keel, it should be fitted towards the side, as far from the keel as possible to avoid false keel echo.

Do not mount transducers close to the propeller or aft of other hull installations (outlets, vents or other protruding details).

It is of course necessary to select a part of the hull that is submerged under all load and speed conditions, and to avoid positions where air is trapped in heavy weather.

If a flat, horizontal section is not available for transducer fitting, the shipyard must construct a suitable bed.

Protect the active element of the transducer and do not paint the surface.

Transmission in the air must be avoided! This may cause mechanical damage of the element.

#### Installation Details.

Refer to SKIPPERs standard installation procedures in the appendix regarding tank installation, welding, Cable glands etc.

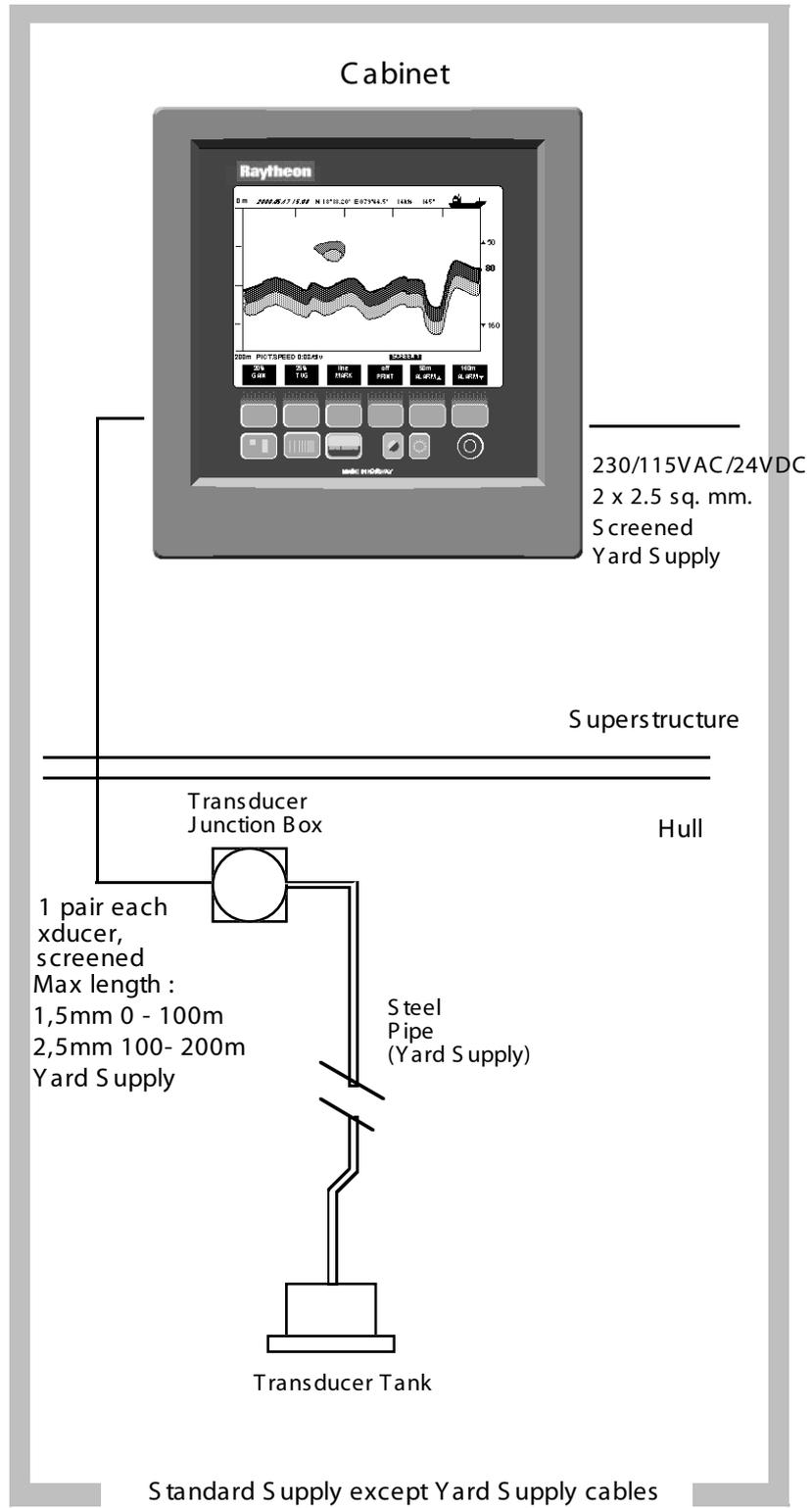

**Fig. 4.1 Basic System Configuration.**

**TRANSDUCER JUNCTION BOX.**

The standard cable fitted on the transducer is 25m or 40m and may be shortened or extended. The junction box is used to interconnect the transducers fixed cable to a yard supply extension cable if the total required cable length is longer than the standard cable. It is recommended to run the standard cable in a steel protecting pipe.

Special requirements apply in areas with Ex conditions. The junction box must always be mounted outside such areas.

Interconnect the transducer pair and its screen in the junction box, **but do not ground the screen here.**

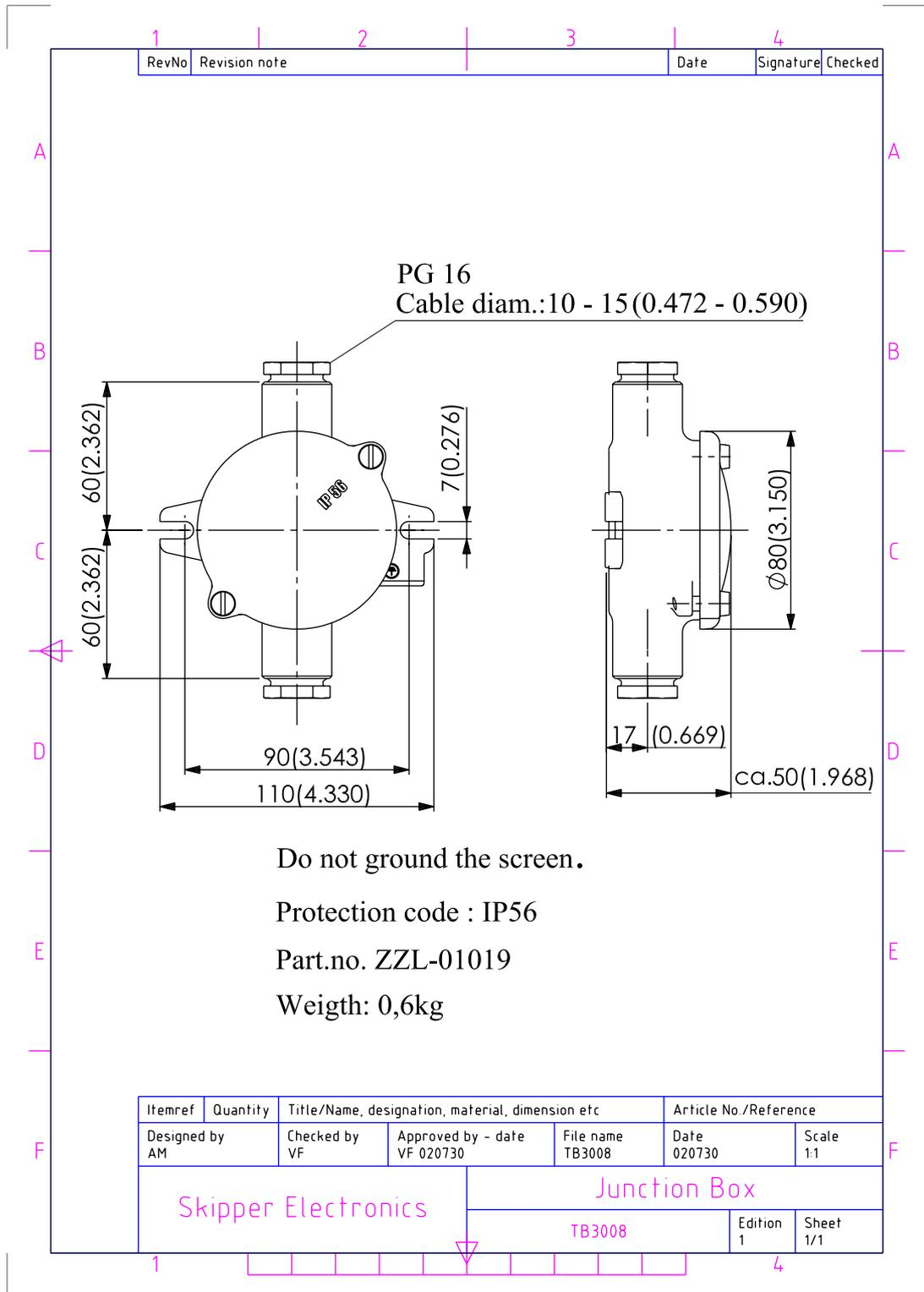

**Fig. 4.2 Transducer Junction Box, Dimensions in mm and (thumbs).**

**OPERATOR UNIT INSTALLATION.**

RevNo	Revision note	Date	Signature	Checked
-------	---------------	------	-----------	---------

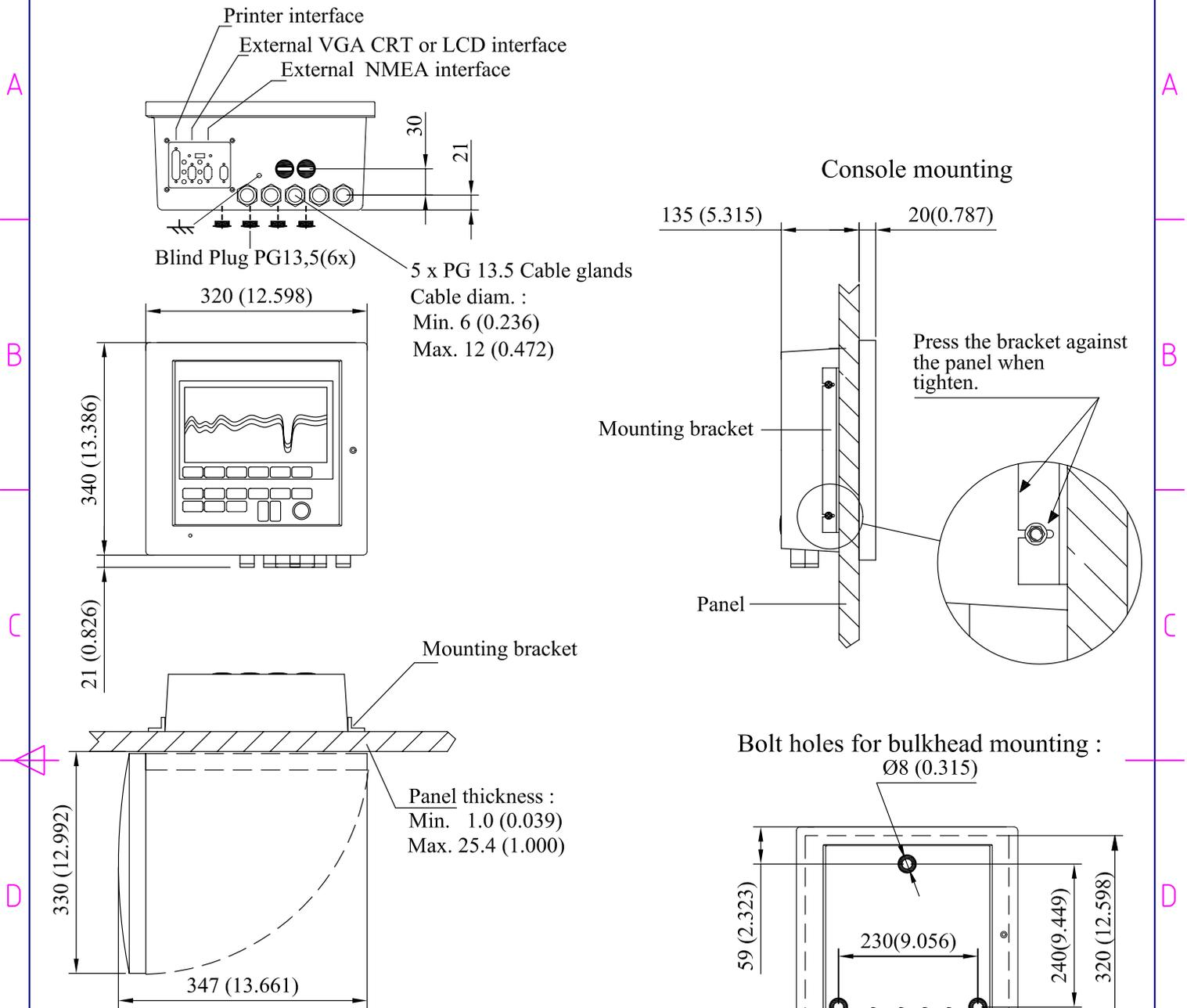

Supply voltage	115/230VAC or/and 24VDC
Current consumption	115VAC/0.6A;230VAC/0.3A;24VDC/2A
Power consumption	70W/AC, 50W/DC
Operating temperature range	-15° C .....+55° C
Storage temperature range	-20° C .....+70° C
Protection code	IP23
Weight	10kg
Distance from magnetic compass : Standard type : 0,4m	
Steering type : 0,25	

Itemref	Quantity	Title/Name, designation, material, dimension etc	Article No./Reference		
Designed by AM	Checked by TW	Approved by - date	File name	Date 2007-01-10	Scale
Skipper Electronics			Dimensional Drawings GDS101		
			TB-3020-Rev-00	Edition	Sheet 1/1

**Fig 4.3 Operator Unit, Dimensions in mm. and (thumbs).**

Select a position to provide free view of the panel as well as easy access during operation and service. The operator unit may be mounted flush in a panel or directly onto a bulkhead. Fig.4.3 shows the operator unit along with the main installation dimensions.

If the unit is to be flush mounted, the shown cut-out and recession depth dimensions must be observed.

Remember to leave room in front of the unit to open the door a full 90 degree.

**Do not perform installation work with system power applied!!**

Cables are led through the appropriate cable glands as follows:

The cable from the transducer(s) should normally occupy the left gland. The right gland is used for power supply connection whereas the centre ones are used for any interface signals connected.

Power supply may be either 230V/115V AC or 24V DC. Power consumption is appx. 50W at 24V, appx. 70W at 115/230V.

The transducer is always connected with 1 pair plus screen. See Fig 4.7.

If the AC power system is 115V, GDS101 may be prepared for 115V AC by re-connecting the connectors J102, J103 as shown in Fig. 4.4

This diagram also shows position of fuses for 230/150 VAC and 24 V DC. These fuses are normal 5 x 20 mm glass fuses.

AC supply:	FS100, FS101	230V	0.5A	Slow blow
		115V	1A	Slow blow
DC supply:	FS102	24V	3.15A	Slow blow

When the installation is complete, and power is connected to the Operator Unit, the appropriate power switch by the power terminals is switched on. For daily operation, these switches may stay on and the unit is switched off by pressing the “SYSTEM off” button on Screen 2. The unit is switched on by pressing any button.

Both 230/115 VAC and 24V DC power may be connected and switched on at the same time. If one of these supplies shuts down, changeover is automatic.

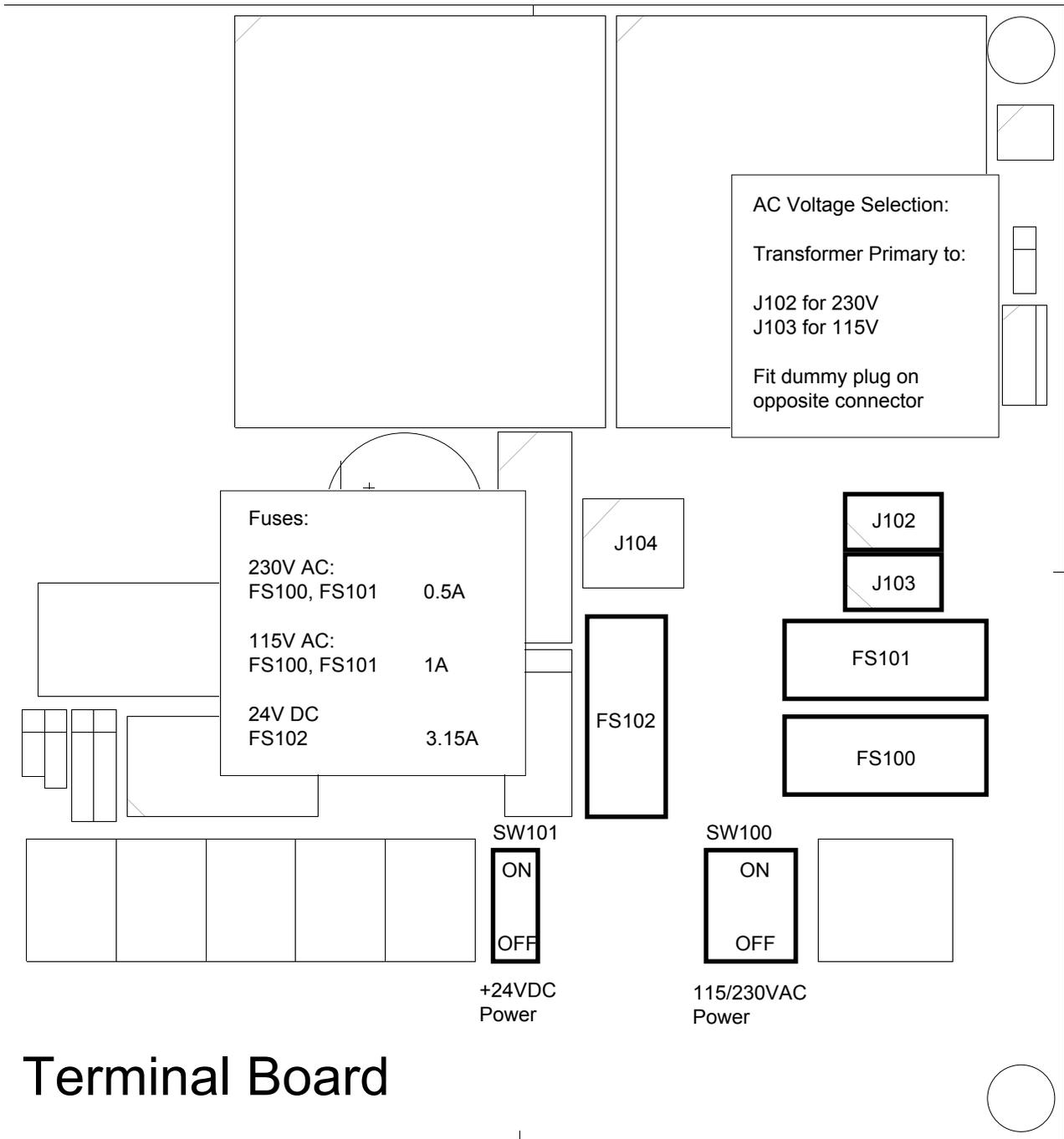

# Terminal Board

**Fig. 4.4 Voltage selection connectors and fuses, Terminal Board.**

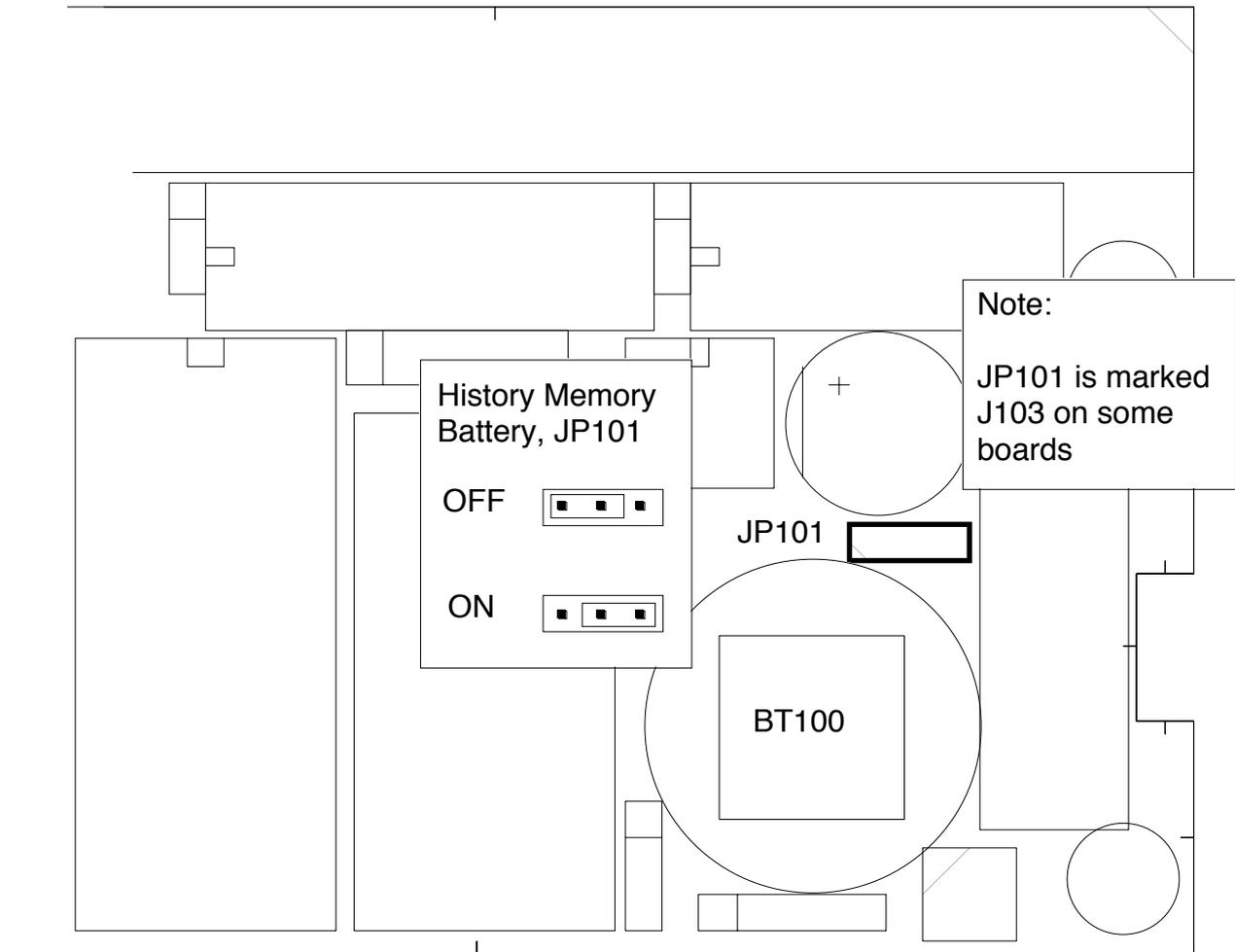

**Fig. 4.5 History Memory Battery Jumper, I/O Board.**

**Back-up Battery Jumper**

After installation is complete and system power is applied, it is necessary to connect the history memory battery to provide power to the History Memory during system power failure. Refer to Fig. 4.5 for the correct setting of the History Memory battery jumper “ON” position. This jumper should be set to the “OFF” position only during extended unit storage periods. The onboard battery is loaded only when no power is applied to the power terminals.

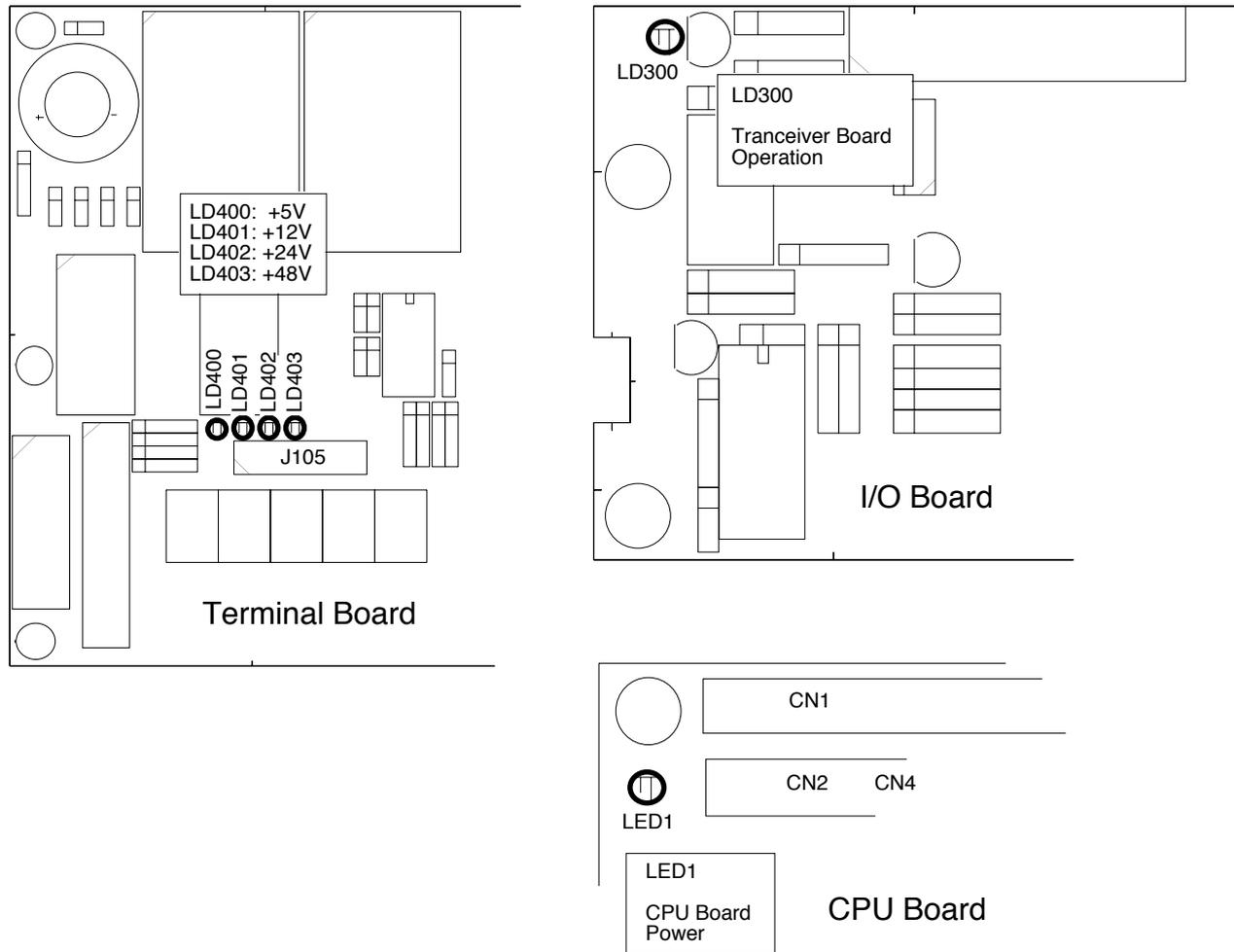

**Fig. 4.6 Function LEDs, Terminal, I/O and CPU Boards.**

**Power Indication and function LEDs.**

The following LEDs are located on the Terminal Board:

LD400	+5V
LD401	+12V
LD402	+24V
LD403	+48V

The following function LED is located on the I/O Board:

LD300	Tranceiver board operation
-------	----------------------------

There is one function LED on the CPU board

LED1	CPU board power
------	-----------------

Fig. 4.6 indicates position of these LEDs.

Fig. 4.7

Main Wiring Diagram.

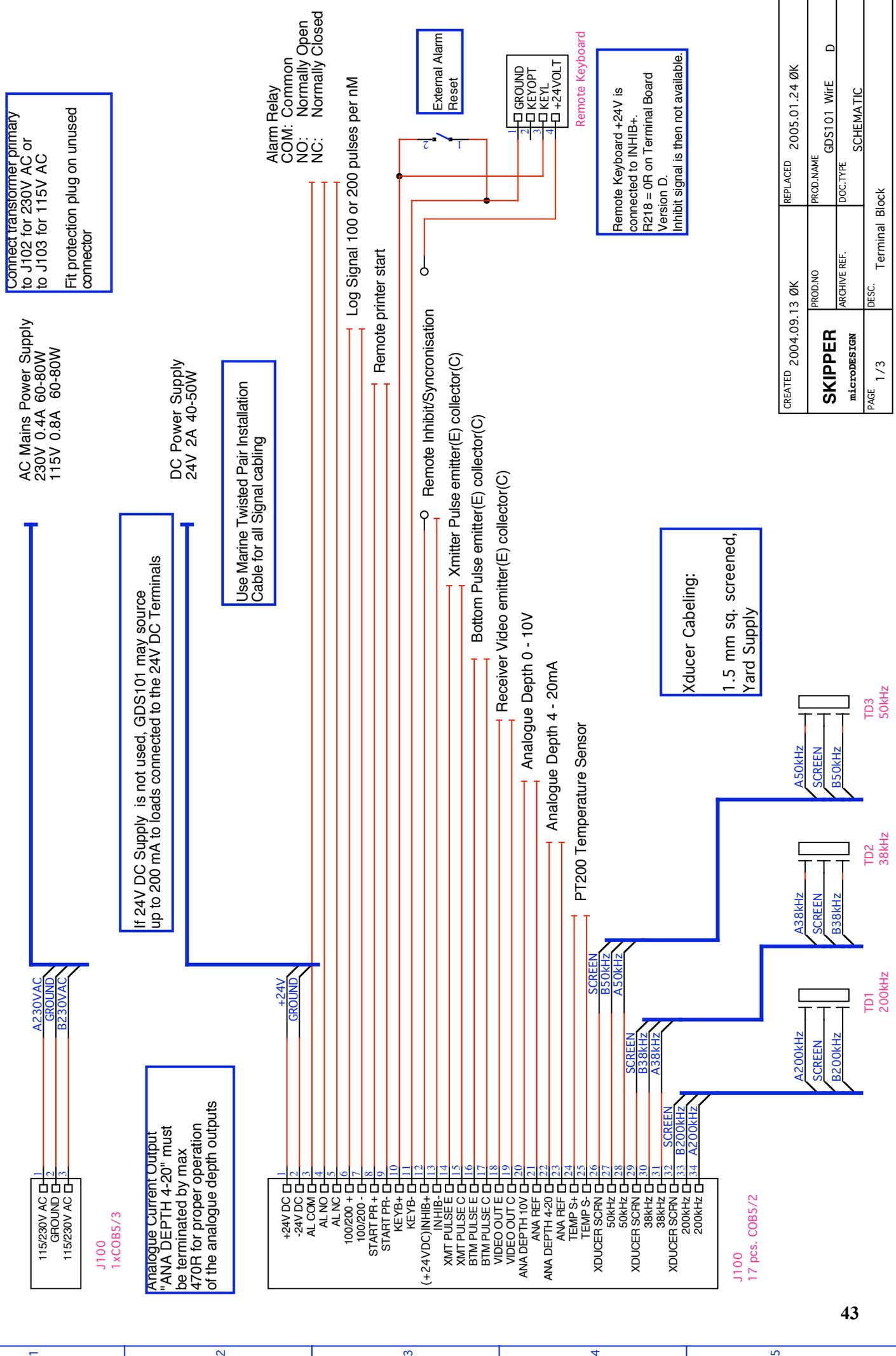

CREATED	2004.09.13 ØK	REPLACED	2005.01.24 ØK
PROD.NO		PROD.NAME	GDS101 WirE D
ARCHIVE REF.		DOC.TYPE	SCHEMATIC
PAGE	1/3	DESC.	Terminal Block

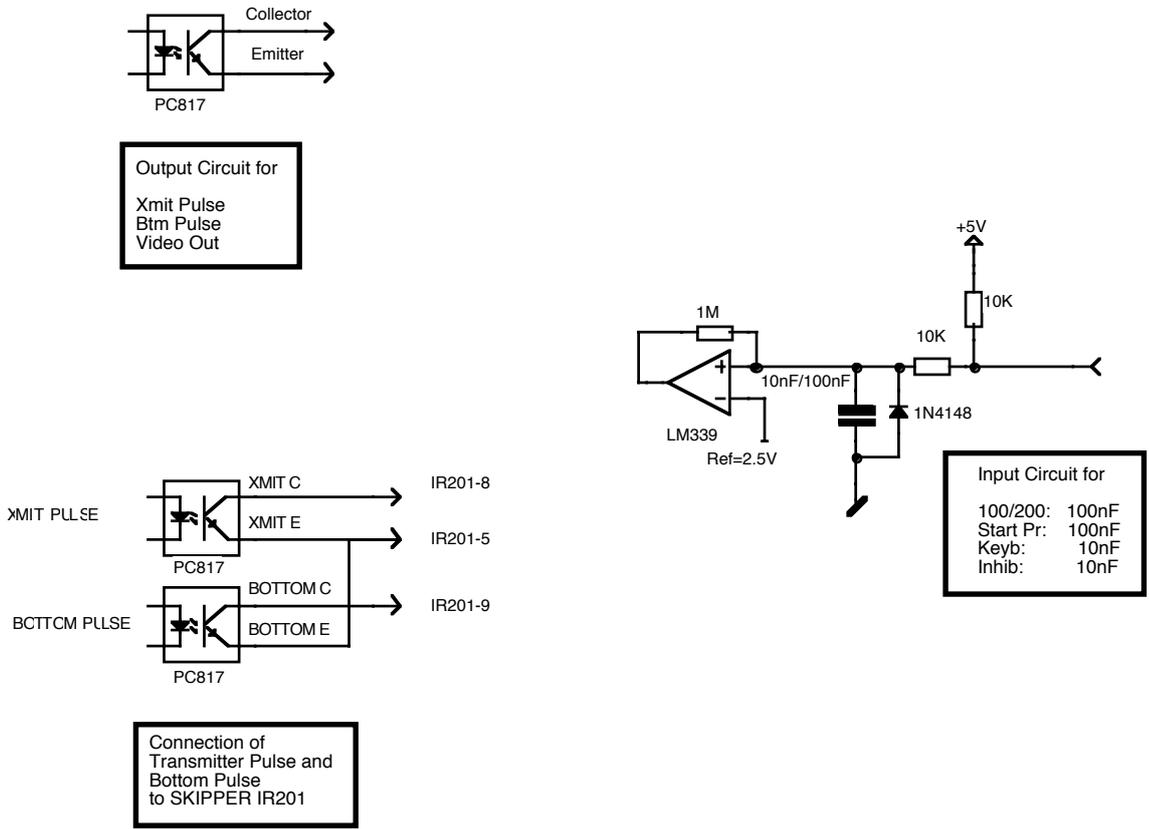

**Fig. 4.8 Input/Output Circuitry.**

**INTERFACING.**

**Alarm relay**

An alarm relay is provided for interconnection to external alarm systems. This relay is normally energised, and is released by alarm conditions or power failure/power off. See Fig. 4.7.

The terminals have the following significance:

- ALCOM Common Terminal.
- ALNC Normally closed Contact (Normal = “No alarm” condition)
- ALNO Normally open Contact

To comply with MED rules, it is mandatory to connect this output to an audible alarm system.

**External alarm reset function**

External alarm reset function.

Can be connected at Key+/Key-, possibly in parallel with external keyboard.

External reset will disengage alarm relay and reset audio alarm (if enabled).

Visual alarm (blinking digital depth indication) is not affected and must be reset locally, by pressing any key on the panel.

External alarm reset terminals are as follows:

- KEYB+ External alarm reset Control Input +.
- KEYB- External alarm reset Control Input -.

### **Log Pulse input**

See Fig. 4.7 and 4.8.

Pulse input terminals are as follows:

100/200 +      Log Pulse Input +.  
100/200 -      Log Pulse Input -.

Refer to Screen 6 for selection of the log pulse rate.

### **Remote Transducer Selector FEEDB (Feedback)**

See Fig. 4.7 and drawing ENS518 in Appenndix

Transducer Selector control input terminals are as follows:

STPRINT +      Transducer Control Input +.  
STPRINT -      Transducer Control Input -.

Transducer selector FORWARD position : (open - FORWARD/PORT transducer selected)  
Transducer selector AFT position : (closed - AFT/STARBOARD transducer selected)

### **Transmitter and Bottom Pulse outputs**

See Fig. 4.7 and 4.8.

Pulse output terminals are as follows:

XMIT C          Collector of Output Opto Coupler, Transmitter Pulse.  
XMIT E          Emitter of Output Opto Coupler, Transmitter Pulse..  
  
BOTTOM C      Collector of Output Opto coupler, Bottom Pulse.  
BOTTOM E      Emitter of Output Opto coupler, Bottom Pulse.

### **Analogue interfaces**

GDS101 is equipped with analogue outputs to supply analogue repeaters or other equipment with analogue inputs. The signals are galvanically connected to the GDS101. Standard range is 0 - 10V or 4 - 20mA corresponding to Shallow Max, Deep Max Settings. These settings may be accessed on Screen 5. See Fig. 4.7.

Analogue outputs from the GDS101 have the following significance:

ANA 10V          Positive analogue voltage output  
ANA REF          Negative analogue reference  
  
ANA 20MA        Positive analogue current output  
ANA REF          Negative analogue reference

## **NMEA interface**

The NMEA outputs provides NMEA0183 format depth information for other equipment with NMEA0183 inputs. Baud rate is 4800 or 9600, 8 bit, No parity. Several messages may be selected on Screen 7 and the enabled messages are transmitted every second.

The NMEA inputs accept position, speed, heading and UTC time messages from various navigators, compasses or speed logs.

The two inputs provided may be connected to different talkers, and both data streams will be received. There are two outputs that will drive each minimum of 10 standard NMEA0183 inputs

The NMEA0183 outputs and inputs are available on the J303 9-pin connector according to the diagram in fig. 4.9.

See Section **5, Start-up and system adaptation**, for a complete list of transmitted and received messages.

Fig. 4.9

Data Communication Interfaces.

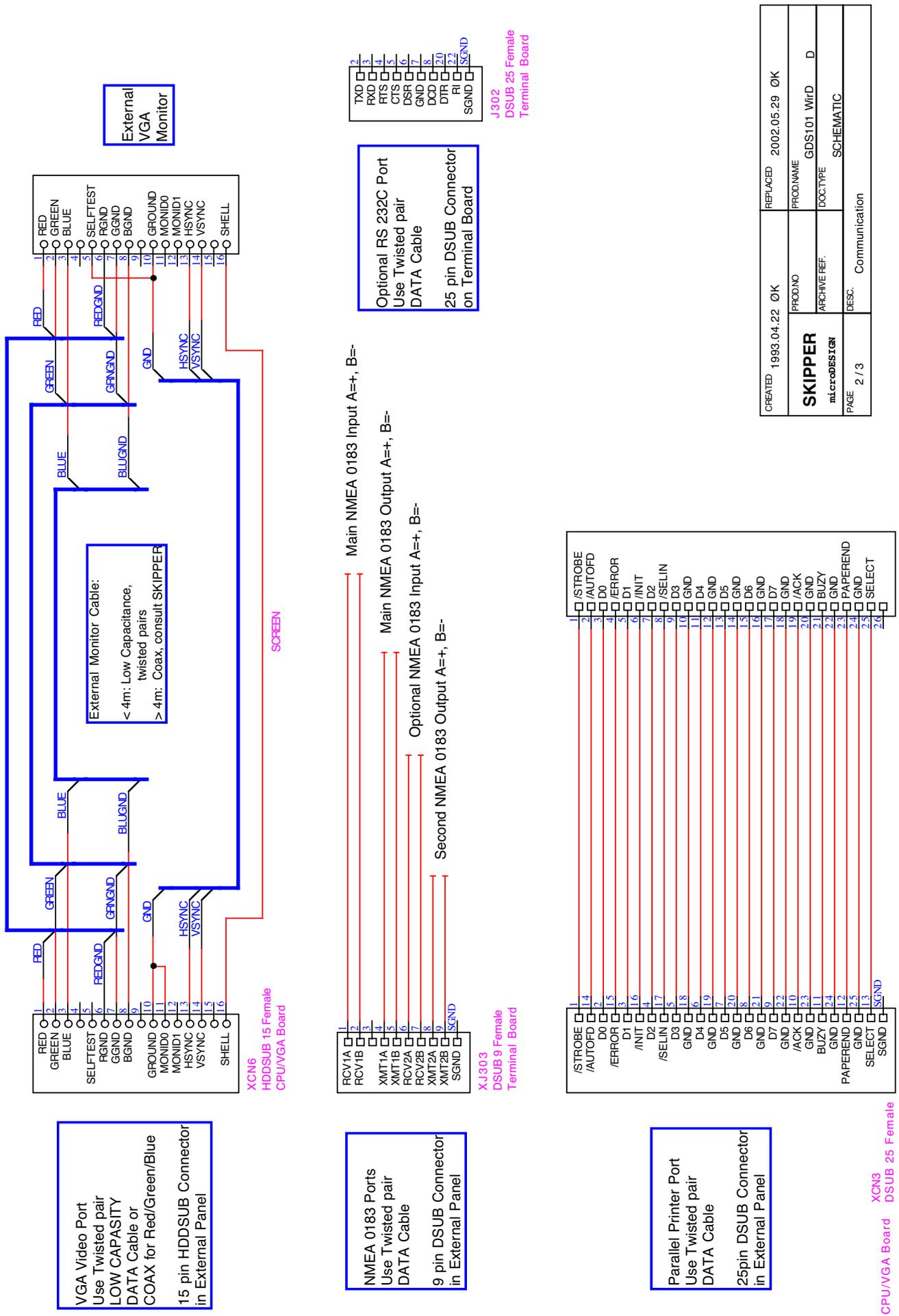

**External Interface Ports**

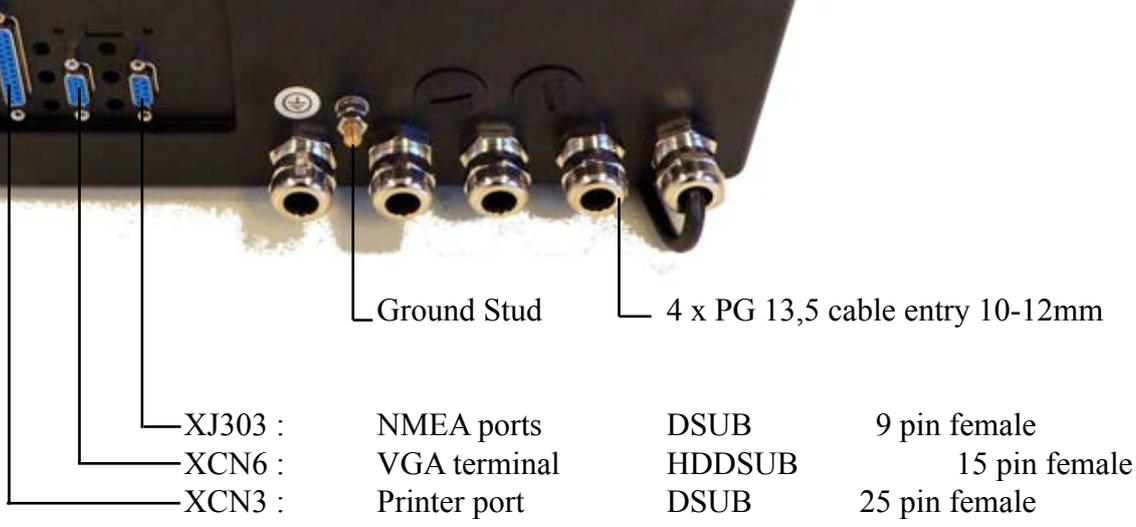

Ground Stud

4 x PG 13,5 cable entry 10-12mm

- XJ303 : NMEA ports      DSUB      9 pin female
- XCN6 : VGA terminal      HDDSUB      15 pin female
- XCN3 : Printer port      DSUB      25 pin female

SEE FIG. 4.9 Data Communication Interfaces.

## OPTIONS.

### **Repeaters/Slaves**

Graphic CRT(VGA) or LCD displays or digital depth slave repeaters may be connected to the system. Along with the graphic display repeaters there may also be installed remote keyboards. The graphic repeaters require the installation of line driver units dependant on the distance between the main system and the repeater.

See Fig. 4.7 and 4.9.

### **Remote Keyboard**

The unit may optionally be operated from a remote keyboard.

KEYB-            Keyboard reference.  
KEYB+            Keyboard signal.

See fig. 4.7 and 4.8

### **Remote Sounding Control.**

This option lets the GDS101 being controlled remotely in synchronised, burst or single ping modes. If installed, these options are accessible on Screen 3.

See Fig. 4.7 and 4.8.

Sounder remote control terminals are as follows:

INHIB +            Control Signal Input +.  
INHIB -            Control Signal Input -.

Refer to Screen 6 for selection of the control signal polarity.

## 5. START-UP AND SYSTEM ADAPTATION

### SYSTEM ADAPTATION

#### **Analogue Output And Log Pulse Input Range Selection.**

From Screen 6 it is possible to set number of pulses per nautical mile (100or200or400) for the log pulse input.

Shallow and deep range limits for the analogue output may also be set, e.g.

50 m corresponding to 10V or 20 mA and

0 m corresponding to 0V or 4 mA.

#### **Language and Units of Measure**

From Screen 5 it is possible to select different languages and units of measure for the screen and printer character strings.

The available languages are: English, French, Spanish, Russian, German and Norwegian.

Units of measure may be selected for:

Depth:	meters, feet, fathoms, braccias.
Picture Speed:	min:sec, nm/div, km/div, miles/div.
Vessel Speed:	knots, km/h, miles/h.
Sound Speed:	m/s, feet/s.

#### **Remote Transducer Selector**

See Fig. 4.7 and 4.8.

Transducer Selector control input terminals are as follows:

STPRINT +	Transducer Control Input +.
STPRINT -	Transducer Control Input -.

STPRINT-/STPRINT+ input is processed as transducer selector input (open - FORWARD/PORT transducer selected, closed - AFT/STARBOARD)

#### **Low frequency indication**

When the 38 KHz transceiver channel has been modified to a different frequency, it is possible from screen 5 to adjust indicated value. Softkey SET LOW has five preset values (24/28/30/33/38 KHz) and encoder must be used to set any other value in the range of 10-200 KHz, when desired. Note that the 38KHz channel must be activated first (Screen 2, button "FREQUENCY").

Also, note that after Master Reset procedure the value is reset to factory default, and should be re-entered, if the actual value is different.

## NMEA Setup

Screen 8 is used for verification of received NMEA messages and control of transmitted NMEA depth messages. Two digital communication channels are provided: primary NMEA 0183 (J303, RCV1A/B-XMT1A/B) and secondary RS232C/NMEA 0183, available on J303 (NMEA: RCV2A/B-XMT2A/B) and J303 (RS232C). Each channel can be programmed individually with respect to the baud rate and scope of transmitted messages. Before configuring of the required channel, it must be selected by the mean of softkey IN/OUT. Primary channel is called NMEA, while secondary - RS232. Note, that text window will represent information, which corresponds to the currently selected channel. The type of displayed messages - received from external talker (if connected) or transmitted by the sounder is selectable by the mean of softkey DISPLAY. For more easy analysis of the window contents, display can be prevented from continuous update, if "DISPLAY off" is selected. The baud rate may be set to 4800 or 9600, 4800 being the more common.

Transmitted messages are enabled individually by the mean of pair of softkeys MESSAGE and STATUS. To enable/disable particular message, select it from the list by pressing MESSAGE button until required message is appeared on the same button and then select the status of this message (on/off) by pressing STATUS button. It is advisable at this stage to set display in "output" mode, to be able to observe current scope of transmitted messages.

Transmitted talker identifier is SD, Sounder Depth. The following NMEA 0183, v3.0 messages may be transmitted:

Depth & Draught	\$SDDP,xxxx.x,xxxx.x,xxxx.x*hh<CR><LF>
Depth below surface	\$SDDBS,xxxx.x,f,xxxx.x,M,xxx.x,F*hh<CR><LF>
Depth below transducer	\$SDDBT,xxxx.x,f,xxxx.x,M,xxx.x,F*hh<CR><LF>
Depth below keel	\$SDDBK,xxxx.x,f,xxxx.x,M,xxx.x,F*hh<CR><LF>
[Fore/Aft] transducer	\$SDXDR,D,x,x,M,c-c,<Cr><Lf>

In case of multiple transducers installation the following SKIPPER proprietary sentence must be selected:

\$SPKPDPT,x.x,x.x,x.x,xx,xx,c-c\*hh<CR><LF>

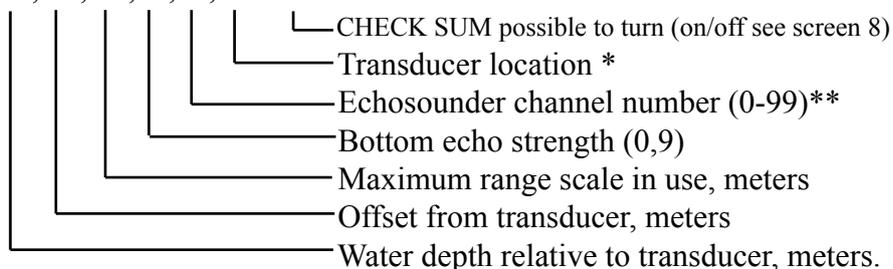

\* Text string, indicating transducer position : FWD/AFT/PORT/STB. If position is not preset by operator, empty field is provided.

\*\* = 1 - 38KHz  
= 2 - 50KHz  
= 3 - 200KHz

The following messages are accepted for input to GDS101 and interpreted by the program. The talker identifier is ignored:

## Time

Universal Time	ZZU,xxxxxx
Universal Time & Local	ZLZ,xxxxxx,xxxxxx,-xx
Day, Month, Year	ZDA,xxxxxx,xx,xx,xxxx,-xx

## Position

Geographical Lat/Lon	GLL,xxxx.xx,N,xxxxx.xx,W
----------------------	--------------------------

Geographical Fix, present	GXP,xxxxxx,xxxx.xx,N,xxxx.xx,W,cccc,x
Loran C Fix, present	GLP,xxxxxx,xxxx.xx,N,xxxx.xx,W,cccc
GPS Position	GGA,xxxxxx,xxxx.xxx,N,xxxxx.xxx,W,x

Heading

Heading, true, present	HDT,xxx.,T
Heading, magnetic, present	HDM,xxx.,M
Heading, compass	HCC,xxx.

Speed

Dual Doppler Vector	VBW,uxx.xx,uxx.xx,a,uxx.xx,uxx.xx,a
---------------------	-------------------------------------

Composite

Loran C specific	RMA,a,xxxx.xx,N,xxxxx.xx,W,,,xx.x,xxx.,,*xx
GPS, Transit specific	RMC,xxxxxx,a,xxxx.xx,N,xxxxx.xx,W,xx.x,xxx., xxxxxx, *xx
Track & Ground speed	VTG,xxx.,T,xxx.,M,xx.x,N,xx.x,K
Heading & Water speed	VHW,xxx.,T,xxx.,M,xx.x,N,xx.x,K

The following messages may be transmitted (Selected from Screen 7 and dependant on the DRAUGHT setting). The messages are enabled individually. Transmitted talker identifier is SD, **S**ounder **D**epth:

**OPTIONS**

**Calibration, Sound Speed.**

The only calibration activity necessary is when the Sound Speed option is installed. In this case, set the required sound Speed value in Screen 3.

**External Ping Control.**

When this option is installed, transmitter operation may be controlled by the external INHIBIT signal. The active polarity of this signal may be set on Screen 6. The following function options are available on Screen 3:

PING	continuous	Transmitter operation is continuous and not affected by the external signal.
	edge	The transmitter is activated <u>once</u> by an active signal edge.
	level	The transmitter is controlled by the external signal level. An active level keeps the transmitter running, a passive level stops the transmitter.
	single	The transmitter is activated ping by ping by pressing the PICTURE SPEED button on the Operator panel. The external INHIBIT signal is disabled.

## 6. SPECIFICATIONS DIMENSIONS

<u>Transducer, 38 kHz</u>	<u>H * W * L</u>	<u>101 * 206 * 255 mm</u>
	Mounting	Tank
	Cable length	40m
	Weight	appx. 20 kg
	Protection	IP 68
<u>Transducer, 50 kHz</u>	<u>Diameter</u>	<u>90 mm</u>
	Mounting	<b><u>Tank and Gate Valve</u></b>
	Cable length	25m or 40m
	Weight	appx. 7 kg
	Protection	IP 68
<u>Transducer, 200 kHz</u>	<u>Diameter</u>	<u>140 mm</u>
	Mounting	<b><u>Tank</u></b>
	Cable length	25 or 40m
	Weight	appx. 8 kg
	Protection	IP 68
<u>Transducer, 200 kHz</u>	<u>Diameter</u>	<u>90 mm</u>
	Mounting	<b><u>Gate Valve</u></b>
	Cable length	25m
	Weight	appx. 7 kg
	Protection	IP 68
<u>Transducer Junction Box</u>	<u>Size incl. glands</u>	<u>132 * 111 mm</u>
	Depth	55 mm
	Weight	0.6 kg
	Protection	IP 56
<u>Operator unit cabinet</u>	<u>Height, front</u>	<u>340 mm</u>
	Width	320 mm
	Depth	170 mm
	Weight	appx. 10 kg
	Protection	IP 23

### FUNCTIONAL PROPERTIES

Display:	10,4" 158 x 211 mm graphic Dot-Matrix super twist color LCD Screen with adjustable day/night vision and Backlight. 640 x 480 pixels.
Printer:	Optional External Printer: Raytheon 104-033 Or specified HP or Epson.( ask for type) All Information is printed.
Depth Alarms	Deep and shallow Limits.
Calendar/Clock	Year-Month-Day / Hours-Minutes-Seconds (24 hour system).
Interface Outputs	Trigger- and Bottom-Pulses. Analogue 4-20mA and 0-10V for Depth. Detected Video. NMEA 0183 for Depth. Alarm Relay. Output for VGA Repeater. RS-232 C. PC Parallel Printer Port

Interface Inputs	100/200 Pulses for Speed. NMEA0183 for Speed, Position, Heading and Time. Temp. Sensor Input. Remote Transducer Selector
Languages	English, French, Spanish, Russian, German and Norwegian.
Options	UDR or IR301 digital remote depth Indicator. LCD Repeater. Remote Keyboard. Remote Sounding Control. Auto Range Sound speed calibration

## Performance

Depth Range:		0 - 1600 m
Graphic resolution:		0.5% of Range
Digital resolution:		<10 m: 0.1 m 10 m: 1 m
Transducer, 38 kHz	Beam Angle	18° * 9°
	Max. Power	1kW
	Effective Range	1600m
Transducer, 50 kHz	Beam Angle	33° conical
	Max. Power	1kW
	Effective Range	1000m
Transducer, 200 kHz	Beam Angle	6° conical
	Max. Power	1kW
	Effective Range	500m

## Environmental according to IEC60945 :

### Transducer and Junction Box

Operating temperature	-15 - 55 degree C IEC60945
Storage temperature:	-20 - 70 degree C
Protection, Transducer:	6 bar
Protection, parts inside hull:	IP66

### Operator Unit Cabinet

Supply voltage:	230V(195-253VAC) or 115V(96-125VAC) 24V DC (20-32V)
Power consumption:	50W at 24V, 70W at 230V or 115V
Alarm relay:	Change-over contact, max. 24V 300 mA
RS232 port:	Standard 25 pin D-Sub Connector.
NMEA port:	9 pin D-Sub. 2 Inputs, 2 Outputs.
Operating temperature:	-15- +55 degree C according to IEC60945 To increase serviceability and life-time, we suggest the working temperature to be held at 0- +40 degrees C.
Storage temperature:	-20 - +70 degree C
Humidity:	10 - 90% relative, no condensation.
Protection	IP 23

## 7. SERVICE

All service requests should be made to the local SKIPPER representative.

Adjustments and repairs should only be performed by qualified service engineers, and Unqualified repair attempts will void the warranty.

Below are the CPU bios settings for the PCA 6135 and PCA-6740. If the unit contains a compact flash holder, the 6740 is in use.

### **CPU Board Setup Procedure.**

( Valid for GDS 101u with connection for external printer and PCA-6135 type CPU with Flash RAM installed.)

#### 1. Hardware.

Jumpers on the CPU board must be set as follows: JP1: 1-2, JP 4: 1-2, JP 9: 2-3, JP14: 1-2, JP15: 2-3.

Remaining jumpers JP 2, JP 3, JP 5, JP 6, JP 7 are not applicable.

Jumpers JP 8, JP 10, JP 12, JP 13 are connectors.

Check that 1 SIMM board ( 4M RAM ) has been properly inserted in the “SIMM 1” bank, and locked.

#### 2: Software.

A. Connect a PC Keyboard to the CPU board.

B. Connect a VGA Screen to the CPU board.

C. Switch the GDS 101 Power “ON” while pressing “DELETE” key.

D. Do not release “DEL” key until several click’s , beep’s and signals have been heard, and picture is present on VGA screen.. Then release key.

If the CPU has been set up before, clicking sound may not be present.

E. VGA screen will show “AMBIOS Hiflex Setup Utility.”

F. Select in menu “Standard CMOS Setup”, using UP/DOWN arrows.

G. Press “Enter” once.

H. Using keys “Arrow UP”, “Arrow DOWN”, will move pointer in menu.

I. To modify parameters use keys “Page UP”, “Page DOWN”.

J. In Standard CMOS Setup, set parameters as follows.

- Date: Weekday-Month-Date-Year.

- Time: Hours - minutes - seconds.

- Floppy drive A: Not installed.

- Floppy drive B: Not installed.

- Pri Master: Not installed

- Pri Slave: Not installed.

- Boot Sector Virus Protection: Disabled

To exit “ Standard CMOS Setup “, press key “ESC”.

K. Select in menu “Advanced CMOS Setup”.

L. Press “Enter” once.

M. Use same method as “H” and “I” to modify parameters.

N. Set “Advanced CMOS Setup” parameters as follows.

- 1st Boot Device: Disabled.
- 2nd Boot Device: Disabled.
- 3rd Boot Device: Disabled.
- 4th Boot Device: Disabled.
- Boot from Card BIOS: No.
- Try other Boot Devices: Yes.
- S.M.A.R.T. for Hard Disks: Disabled.
- Boot Up Num Lock: On.
- Floppy Drive Swap: Disabled.
- Floppy Drive Seek: Disabled.
- Floppy Access Control: Normal.
- HDD Access Control: Normal.
- System Keyboard: Absent.
- Primary Display: VGA/EGA.
- Password Check: Setup.
- System BIOS Cacheable: Enabled.
- C000,32K Shadow: Disabled.
- C800,32K Shadow: Disabled.
- D000,32K Shadow: Disabled.
- D800,32K Shadow: Disabled.
- E000,32K Shadow: Disabled.
- E800,32K Shadow: Disabled.

To exit “Advanced CMOS Setup” use key “ESC”.

O. Select in menu “Advanced Chipset Setup”.

P. Press “Enter” once.

Q. Set “Advanced Chipset Setup” parameters as follows.

- AT Bus Clock: 14.318/2.
  - Slow Refresh: 120 us.
  - Memory Hole At 15-16M: Enabled.
  - RAS Precharge Time: 3.5T.
  - RAS Active Time Insert Wait: Disabled.
  - CAS Precharge Time Insert Wait: Disabled.
  - Memory Write Insert Wait: Disabled.
  - Memory Miss Read Insert Wait: Disabled.
  - ISA Write Cycle End Insert Wait: Enabled.
- 
- I/O Recovery: Enabled.
  - I/O Recovery Period: 0.75us.
  - On-Chip I/O Recovery: Disabled.
  - 16Bit ISA Insert Wait: Enabled.

To Exit “Advanced Chipset Setup”, press key “ESC”.

R. Select in menu “Power Management Setup”.

S. Press “Enter” once.

T. Set parameters as follows:

- Power Management Mode: Disabled.

All other options will be disabled automatically.

To exit "Power Management Setup", press key "ESC".

U. Select in menu "Peripheral Setup".

V. Press "Enter" once.

W. Set parameters as follows.

- Onboard SSD:	Disabled.
- Harddisk Delay:	Disabled.
- Onboard IDE:	Disabled.
- Onboard FDC:	Disabled.
- Floppy Drive Swap:	Disabled.
- Onboard Serial Port 1:	3F8h/COM1.
- Onboard Serial Port 2:	2F8h/COM2.
- Onboard Parallell Port:	378h.
- Parallell Port Mode:	Normal.
- EPP Version:	N/A.
- Parallell Port IRQ:	7.
- Parallell Port DMA Channel:	N/A.

To exit "Peripheral Setup", use key "ESC".

X. Select in menu: "Save Settings and Exit", and "Enter".

Y. Confirm "Y", and "Enter".

Wait until "Hit Alt-S" appears on screen.

Press key "Alt" and hold it down, then you press key "S".

A small blue menu should now appear on the screen.

Set the parameters:

SSD IC TYPE:	FLASH 512k.
MEMORY SEGMENT WINDOW:	E 000-E1FF.
SSD DRIVER EMULATED:	2 ND.
WRITE TO SSD EPROM AND EXIT:	Press "Enter."

VGA Screen will now show normal echogram in colours.

GDS 101u LCD Screen will show normal echogram.

Disconnect external keyboard and VGA Monitor.

## CPU 6742

Later versions of the the CPU incorporate a compact flash disk for ease of upgrade and logging. A new CPU is also used and this has the following BIOS settings (Bios version 1.12). The PCA 6742 has the default settings with the following changes

Start by loading the optimised defaults, and then change the following

## 6742 CPU SETUP :

### STANDARD CMOS FEATURES

Date	Change to todays date
Time	Change to time now
HALT ON	NO ERRORS

### Advanced BIOS Features

- a. Hard Disk priority [Press enter] - Press enter
  - i. 1 should be ch.1 M.
  - ii. 2 should be ch0 M.
- b. First Boot Device [Hard Disk]
- c. Second Boot Device [Hard Disk]
- d. Boot other device [Disabled]

### Advanced Chipset features

- a. SMI712 VGA Settings [Press Enter] - Press enter
  - i. SMI712 VGA Monitor [Simul monitor]
  - ii. Panel resolution Mode [640x480 TFT]
- b. USB Device Setting [Press Enter] - press enter
  - i. USB1.0 emulation [Disabled]

### Integral Peripherals

- a. Onboard serial Port 3 [enter]
  - i. Change to [2E8/IRQ9]
- b. Onboard serial Port 4 [enter]
  - i. Change to [3E8/IRQ5]
- c. Parallel Port Mode [EPP]
- d. EPP Mode Select [EPP1.9]

### PnP/PCI Configurations

- a. Resources Controlled By [Manual]
- b. IRQ Resources [Enter]
  - i. IRQ - 7 assigned to [Legacy ISA]
  - ii. IRQ - 10 assigned to [Legacy ISA]
  - iii. IRQ - 11 assigned to [Legacy ISA]
- c. NO DMA

### PC Health Status

- a. Case Open Warning [Disabled]

SAVE SETTINGS AND EXIT

## CPU 6740

Later versions of the the CPU incorporate a compact flash disk for ease of upgrade and logging. A new CPU is also used and this has the following BIOS settings. The PCA 6740 has the default settings with the following changes

Start by loading the optimised defaults, and then change the following

### 6740 CPU SETUP :

```

                                     STANDARD CMOS FEATURES
Date                                 Change to todays date
Time                                 Change to time now
IDE PRIMARY MASTER                  SANDISK SDCFH - XXXX
IDE PRIMARY SLAVE                    NONE
IDE SECONDARY MASTER                SANDISK SDCFH - XXXX
DRIVE A                              NONE
HALT ON                              NO ERRORS

                                     Advanced BIOS Features
First boot device                    HDD-1
Second boot device                   HDD-0
Third Boot device                    Disabled
Boot other device                    Disabled
Swap floppy Drive                    Disabled
Boot up floppy seek                  Disabled

                                     INTEGRATED PERIPHERALS
ONBOARD FDC CONTROLLER              DISABLED
ONBOARD PCI ETHERNET CHIP            DISABLED
PANEL TYPE                           640X480 TFT

                                     PNP/PCI CONFIGURATIONS
RESOURCES CONTROLLED BY              MANUAL
IRQ RESOURCES                         PRESS ENTER - GO INTO THIS MENU
    IRQ-11 ASSIGNED TO                 LEGACY ISA

SAVE SETTINGS AND EXIT
```

## **MASTER RESET PROCEDURE.**

After completed Set-up Procedure you should always do a ‘MASTER RESET’:

Switch off the GDS 101u, using the internal toggle switch and wait for 20 seconds.

Then press down and keep pressed the softkey to the far right and far left ( No. 1 and 6.) in the upper row on the GDS101u keyboard.

Turn the GDS101u ‘on’ and keep the two softkeys pressed down until the screen shows the normal picture. This may take as long as approx. 30 seconds.

You should normally hear 4 ‘beeps’ at the end of the procedure.

Check screen 9. IC 1, 2 and 3 should now indicate OK.

Check screen 7. HISTORY should now start counting from Zero.

## 8. APPENDIX Miscellaneous Installation Drawings

**For Repeater and repeater dimmer see separate manual:**

IR301 Manual

**For Tank and Gate valve see separate manuals :**

ETNSLJB-Manual                      Single bottom gate valve (discontinued from 2007)

SB-100-Manual                      Single bottom gate valve (from 2007)

DB-100-Manual                      Double bottom gate valve (from 2007)

SB-200-Manual                      For 24 and 38kHz transducer deep sea.

StandardTankInstMan For 50 and 200kHz transducer

ComboTankInstMan                For 24 and 38kHz transducer deep sea.  
And for different type of transducers. Custom design possible.

All manuals available on the Skipper homepage or on request : [www.skipper.no](http://www.skipper.no)

Transducer Selector  
For / After

1 PAIR EACH  
XDUCER  
1,5MM  
SCREENED  
YARD SUPPLY

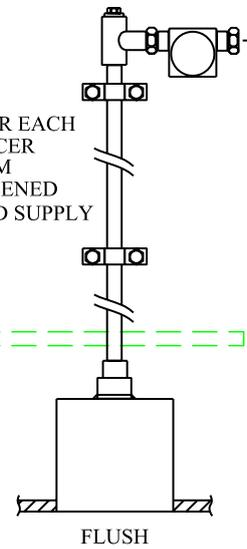

FLUSH

9

8

SHIELD

- 200KHZ 34
- 200KHZ 33
- SCRN 32
- 38KHZ 31
- 38KHZ 30
- SCRN 29
- 50KHZ 28
- 50KHZ 27
- SCRN 26
- TEMP S - 25
- TEMP S + 24
- ANAREF 23
- ANA 20MA 22
- ANAREF 21
- ANA 10V 20
- VIDEO C 19
- VIDEO E 18
- BOTTOM C 17
- BOTTOM E 16
- XMIT C 15
- XMIT E 14
- INHIB - 13
- INHIB + 12
- KEYB - 11
- KEYB + 10
- STPRINT - 9
- STPRINT + 8
- 100/200 - 7
- 100/200 + 6
- AL NC 5
- AL NO 4
- AL COM 3
- 24VDC 2
- + 24VDC 1

GDS 101 POWER  
& TERMINALS

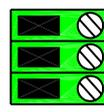

2x0,5MM SQ.WITH SCREEN

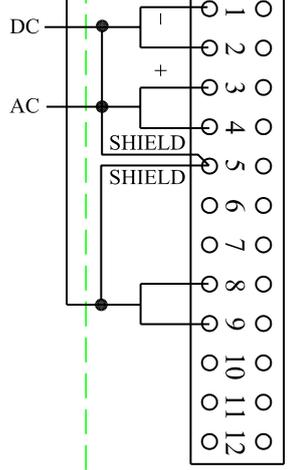
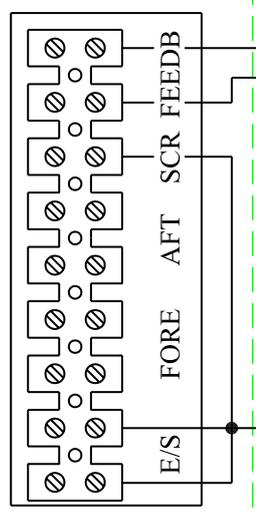

Itemref	Quantity	Title/Name, designation, material, dimension etc			Article No./Reference	
Designed by AM	Checked by VF	Approved by - date	File name	Date 2007-01-08	Scale	
SKIPPER Electronics AS				GDS101 POWER & TERMINALS		
				TB-3006-Rev-01		Edition

Weight	10kg
Distance from magnetic compass :	Standard type : 0,5m
Distance from magnetic compass :	Steering type : 0,5m

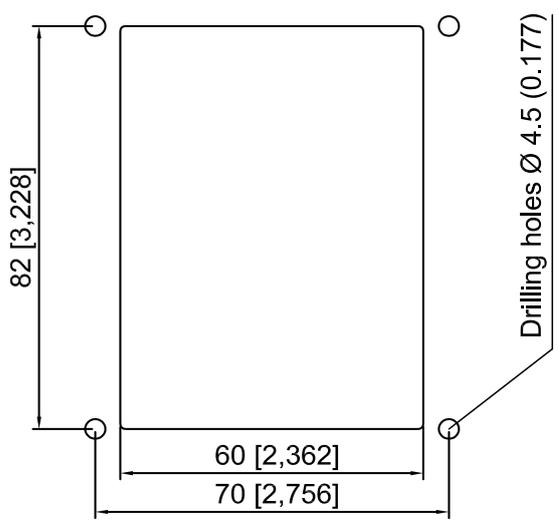
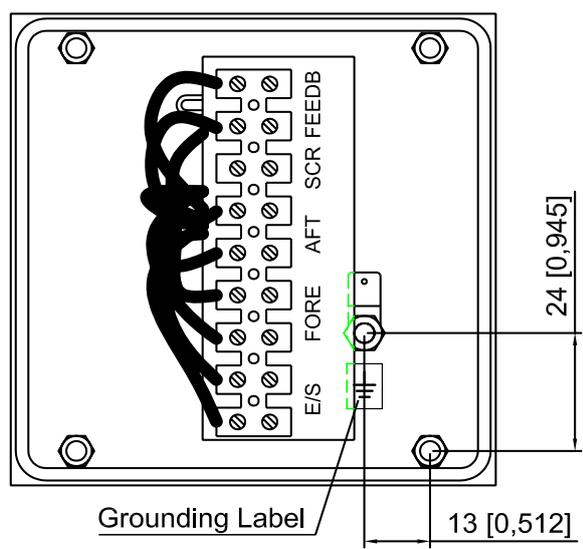
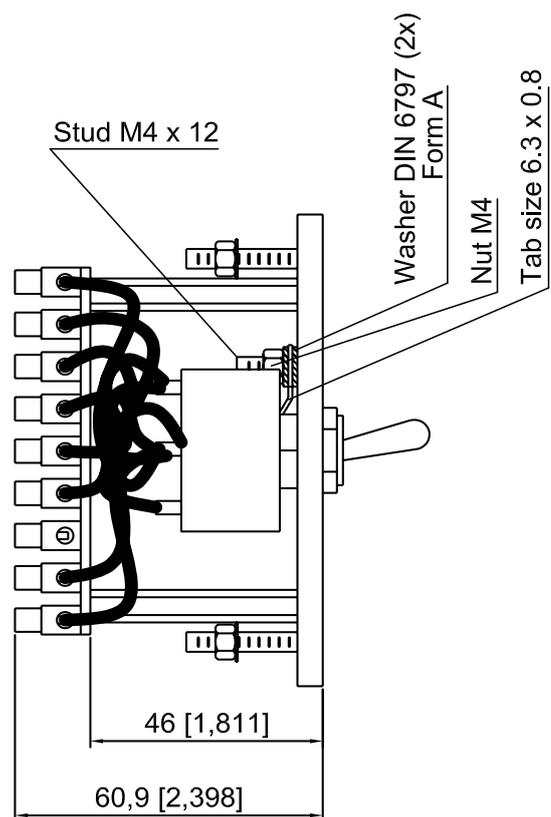
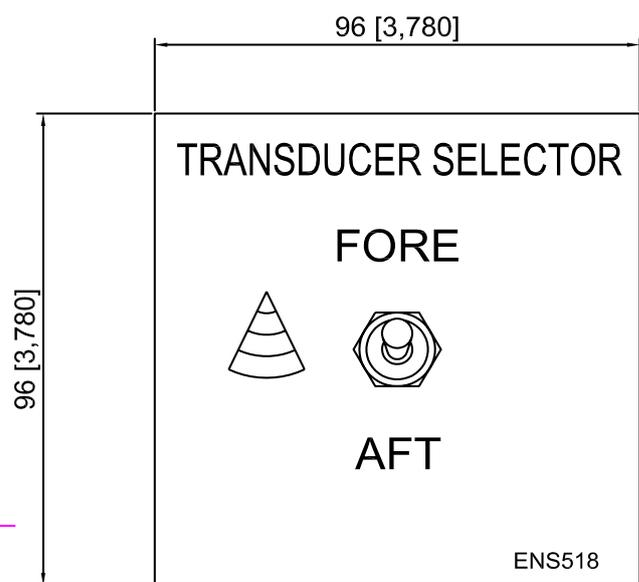
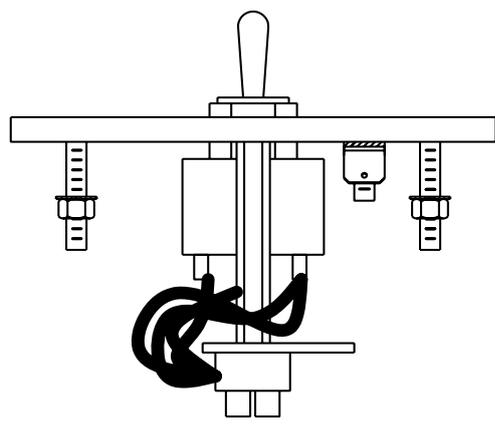

Itemref	Quantity	Title/Name, designation, material, dimension etc	Article No./Reference		
Designed by AM	Checked by VF	Approved by - date VF-020815	File name ENS518	Date 020815	Scale 1:1
SKIPPER Electronics AS			TRANSDUCER SELECTOR		
			ENS518		Edition 0

### 1. Straight braided screen

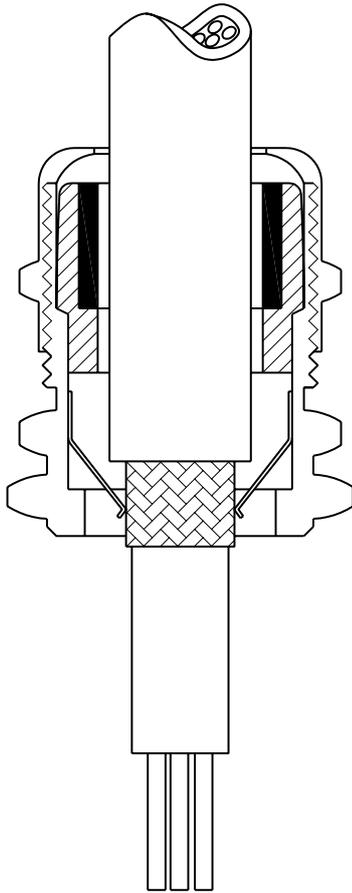

### 2. Twisted backward .....braided screen

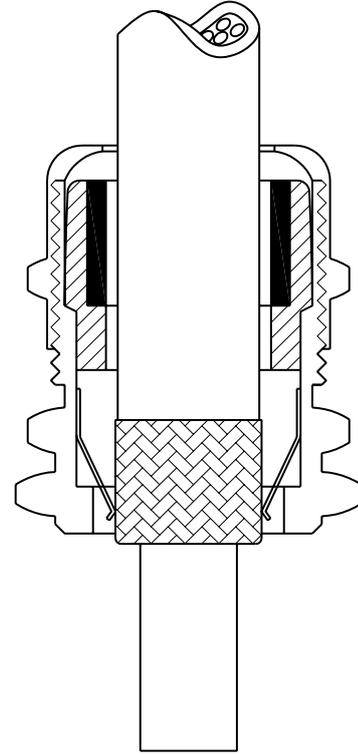

*The assembly of cable gland is quick and easy:*

- 1. Partially expose the braided screen by removing the outer sheath of the cable at a length of approx. 10 mm*
- 2. Insert the cable through the dome nut and the gland body until the contact spring is pressed against the braided screen.*
- 3. Firmly screw on dome nut .*

*Cable glands play an important part in safeguarding EMC requirements where cables and leads enter into a shielding system. They have to ensure a permanent connection with very low ohmic or inductive resistance between the cable shield and the housing potential.*

Itemref	Quantity	Title/Name, designation, material, dimension etc		Article No./Reference	
Designed by AM	Checked by VF	Approved by - date VF - 2006.12.18	File name	Date	Scale
SKIPPER Electronics AS			EMC Cable Gland Connection		
			TB-3015-Rev-00	Edition	Sheet 1/1 64

